

Article

BERSAUDARA Robot (Room and Air cleaner) as a prevention of the spread of viruses in work areas in buildings and isolation rooms

Agus Siswoyo ^{1*}, Eko Aris Cahyono ², Rodik Wahyu Indrawan ^{1,2}

¹ Department of Mechatronics, Universitas Sanata Dharma, Sleman, Indonesia

² Department of Robotics and Artificial Intelligence Engineering, Universitas Airlangga, Surabaya, Indonesia

* Correspondence: woyo@usd.ac.id

Abstract: BERSAUDARA Robot innovation emerged based on health protocols in the new normal era and workers' anxiety about the spread of viruses in buildings. This robot is designed by utilizing the development of robotics technology, Remote Operated Vehicle (ROV), vacuum floor cleaner, and air purifier equipped with UV Sterilizer and HEPA Filter. BERSAUDARA Robot innovation is expected to fulfill the protocol for preventing the spread of the Covid-19 virus, especially work areas in buildings or isolation rooms, by cleaning floors and air regularly so as to minimize human contact and support the continuity of the activities of workers during the "New Normal".

Keyword: Mobile Robot; Remote Operated Vehicle (ROV); Covid-19; Hepa filter.

1. Introduction

Coronavirus Disease 2019 (COVID-19) is a new type of disease that has never been previously identified in humans. The virus that causes COVID-19 is called Sars-CoV-2. On January 30, 2020 WHO has declared it a Public Health Emergency of International Concern (KKMMD/PHEIC) [1]. This virus was identified as being able to transmit from human to human through droplets, infecting all ages. In particular, humans with weakened immune systems have a higher risk of infection.

As an effort to prevent the spread of the COVID-19 virus, the government has made a handling program, one of which are health protocols starting from wearing masks, diligently washing hands, always keeping a distance to avoid physical contact and guidelines for activities during the new normal order or "New Normal". The Minister of Health of the Republic of Indonesia Number HK.01.07/MENKES/328/2020 for the prevention of transmission in the work area has also provided guidance on pandemic situations, namely providing safe and healthy workplace facilities, regular cleaning, appropriate disinfectants (every 4 hours), and maintain workplace air quality by optimizing air circulation. The activities of managing cleanliness and sanitation of work areas in buildings or isolation rooms are currently still carried out manually with limited personal protective equipment and lack of availability of air circulation, especially in areas within the building, thus creating a risk of spreading transmission to officers and workers who are active in the building.

BERSAUDARA Robot innovation emerged on health protocols regulations in the new normal era and from workers' anxiety about the spread of viruses in buildings. This robot is designed by utilizing the recent development of robotics technology, Remote Op-

Citation: Siswoyo, A.; Cahyono E. A.; Indrawan, R. W. BERSAUDARA Robot (Room and Air cleaner) as a prevention of the spread of viruses in work areas in buildings and isolation rooms. *RiesTech* 2023, 1, 3. <https://doi.org/00.000/xxxxx>

Academic Editor: Iwan Susanto

Received: 16 September 2022

Accepted: 14 November 2022

Published: 1 January 2023

Publisher's Note: MBI stays neutral with regard to jurisdictional claims in published maps and institutional affiliations.



Copyright: © 2023 by the authors.

Licensee MBI, Jakarta, Indonesia.

This article is an open access article distributed under MBI license (<https://mbi-journals.com/licenses/by/4.0/>).

erated Vehicle (ROV), vacuum floor cleaner, and air purifier equipped with UV Sterilizer and HEPA Filter. The stages in making the robot begin with design planning, initial testing, stage I validation, stage II validation, and the implementation. BERSAUDARA Robot innovation is expected to fulfil the protocol of preventing the spread of the Covid-19 virus, especially in work areas of buildings or isolation rooms, by cleaning floors and air regularly so as to minimize human contact and support the continuity of the activities of workers during the "New Normal". This research is also in line with the objectives of the 2016-2020 Sanata Dharma University Research Master Plan, which is to develop knowledge, produce innovations that are able to solve independent and sustainable problems for the community, and be proactive in the demands of strategic environmental developments.

2. Materials and Experiment Methods

A. Analysis

Sensor for mapping, localization, and navigation of mobile robots rely heavily on available information about the state of the robot and the environment. Typical sensors for mapping are:

1. The odometry is usually calculated from the measurements of the encoder mounted on the wheel. It can estimate the displacement of the robot, but the accumulation of errors makes its application unfeasible, as a unique source of information, in real applications.
2. GPS (Global Positioning System) is a good option outdoors, but loses its capability near buildings, on narrow streets, and indoors.
3. SONAR (Sound Navigation and Ranging) allows measurement of the distance to objects located in the vicinity, through the emission of sound pulses and measurement of the reception of echoes from these pulses. However, the precision is relatively low, as it tends to present high angle uncertainty and some noise caused by reflected sound signals.
4. The laser sensor determines the distance by measuring the flight time of the laser pulse as it bounces off a neighboring object. Their precision is higher than that of SONAR, and they can measure distances from centimeters to tens of meters with relatively good angular precision and resolution.

B. Design

BERSAUDARA robot is designed to have an omnidirectional movement mechanism so that it can walk in every corner of the workplace or isolation room, this robot is equipped with a remote-control system, floor cleaner, and air purifier.

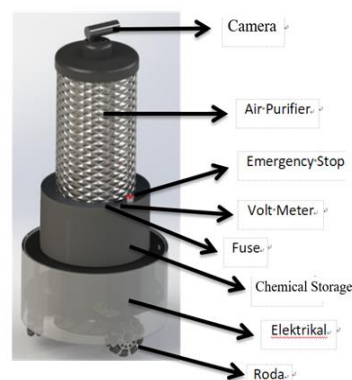

Figure 1. Design BERSAUDARA robot



Figure 2. Design BERSAUDARA robot

The mechanical design of this robot supports its ability to move in the terrain. The material components of the robot use aluminum for both the base and its upper body construction. Aluminum was chosen because it is relatively easy to adjust/form and its lightweight gives an advantage when the robot is maneuvering in a narrow room.

C. Development

Map Building and Subsequent Localization

Solving the localization problem requires a pre-built environmental model, so that the robot is able to position and route itself by comparing its sensory information with the information captured in the model.

This robot itself is a development of a prototype automated guided vehicle, which is useful for Covid-19 hospitals. The tools attached in the robot was equipped and developed to assist and solve air and air problems. The tool is controlled using a Cytron ps2 remote with visuals captured by the DDPAI camera. The microcontroller system activates Mega 2560, this is to activate three IBT-2 to lift or run the PG45 motor and one DC relay to trigger the switch from the vacuum cleaner.

In this tool there is also an air purifier which is activated manually not with a microcontroller. This air purifier source connection is supplied by an AC voltage of 220 generated by a DC to AC inverter. The connection needed for this tool is supplied by 2 batteries in parallel to produce a 24 Volt DC voltage needed to lift or run the PG45 motor. This 24V voltage is reduced by two step downs to 12V to supply the inverter and 9V to activate the power while the power of three IBT-2 is supplied directly by the 5V pin.

D. Testing

Figure 4 shows a block diagram of a Bersaudara Robot system. This robot uses a PG45 24VDC motor, BTS 7960 as a motor driver, sensor input, vacuum cleaner output, air purifier, and Arduino to develop the system. The operation of the sister robot will be based on taking data from a series of inputs that will tell the condition of the space around the hospital patient room. These inputs include ultrasonic, limit switch sensor, and digital compass. Each of these sections will be described in more detail later in the documentation. The data from this input will be entered into a chip which through its software program will decide which direction the robot should move by sending a control signal to the driving motor.

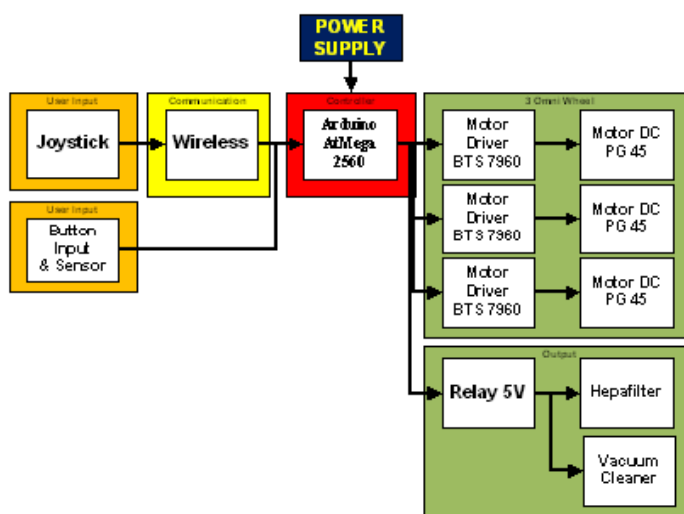

Figure 3. Block diagram of BERSAUDARA robot

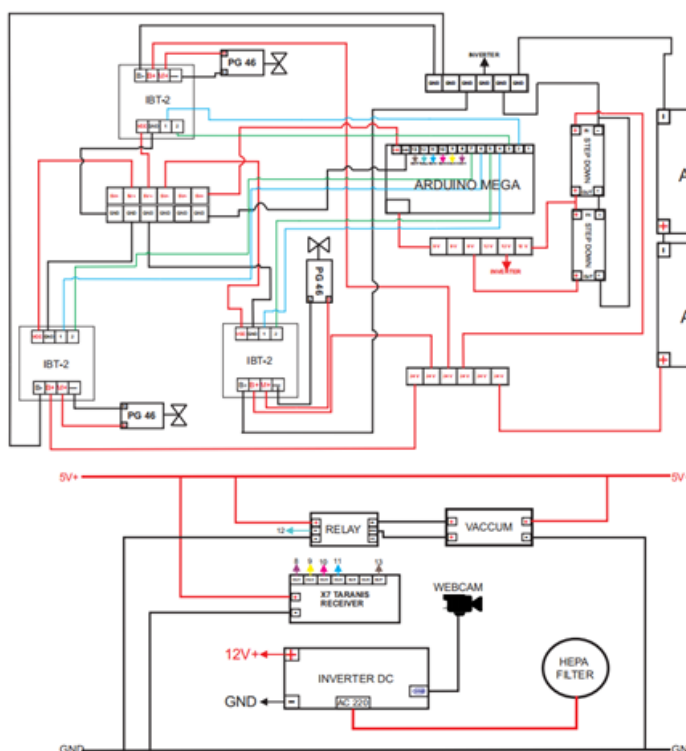

Figure 4. Robot Wirings

The wiring circuit in Figure 4 uses a voltage source from a 12 volt dc lippo battery to supply the controller system, from sensor input, controller and dc motor output. There is an inverter to convert the 12 volt dc voltage to 220 volts to supply the air purifier and webcam camera. for floor cleaning using a voltage of 12 volts dc.

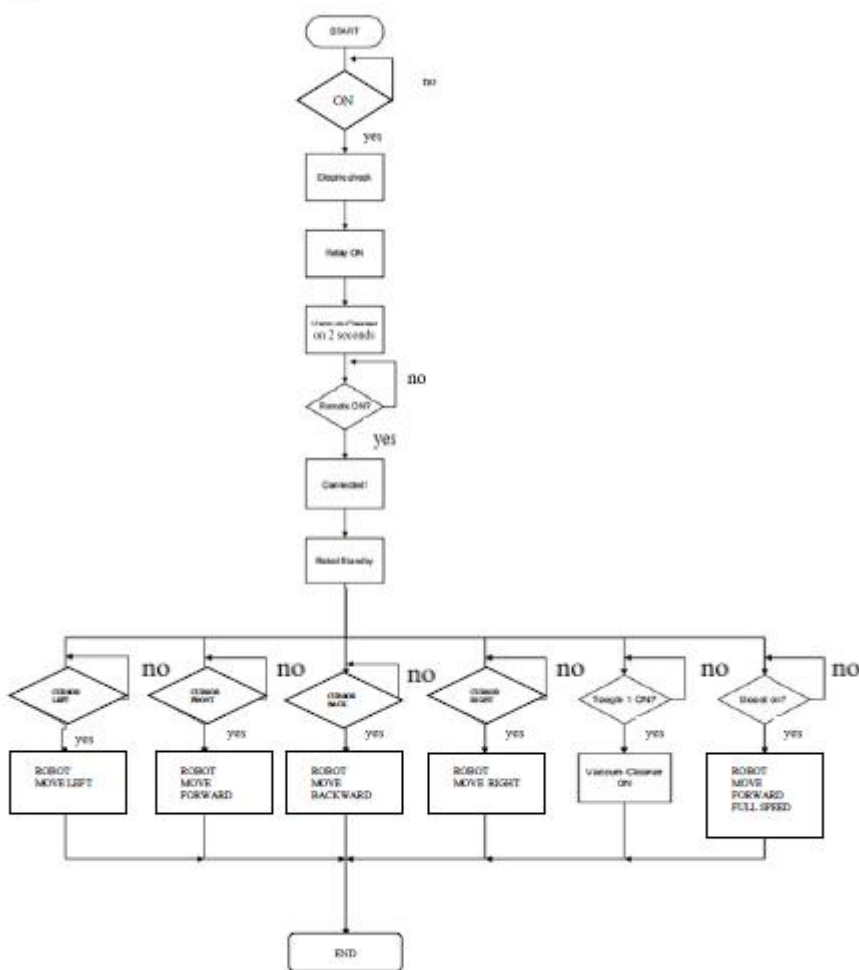

Figure 5. Flowchart

In this research I used a manual wireless controller, so we only need to press the push navigation button on the Playstation 2 wireless controller and the robot is controlled manually with a remote to bring the robot closer to or in front of the door of the COVID-19 patient room with a camera guide located above the robot. When it arrives in front of the patient's room, the robot will switch to automatic mode, will turn on the floor cleaner and air purifier, the robot will automatically enter the room itself to clean the room and air until it reaches every corner of the room. after that the robot will return to the door again.

E. Configuration and Analysis

The results of the analysis of the needs of the floor cleaning robot system developed include:

- a. Robot can work with maneuvering in all directions with the conditions of various shapes of the room.
- b. Robots that are built have a cleaning system in the form of polishing machines and vacuum cleaners.
- c. The robot motor operates with a 24V DC voltage.
- d. Minimum battery voltage of 12 V with a current of 20Ah
- e. Wireless control is needed to reach in all directions.

The hardware and software design developed in the floor cleaning robot includes the design of locating the drive wheel, vacuum cleaner motor and air purifier equipped with UV Sterilizer and HEPA Filter. It also developed the design of wireless communication devices between robots and joystick. Robot drive wheel consists of three motors that form a triangular configuration. The motor is placed at the end of the triangle to move the angle of the omni wheel, so it is easy to move. The design of the placement of the robot motor is shown in Figure 10.

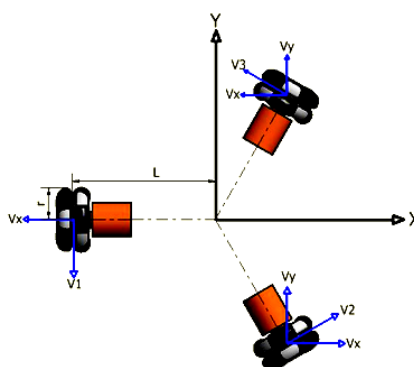

Figure 6. The design of robot’s wheels placement

The results of the placement of the wheel design are also used as a reference to place a vacuum cleaner. The placement of the vacuum motor is placed on the back or base of the triangle from where the wheels are placed. A vacuum cleaner is placed in front of so that the floor is free of dust before being polished by. The results of the placement of the motor wheel, motor vacuum cleaner and second floor polisher motor are shown in Figure 2.



Figure 7. The design of the vacuum motors

E1. Human Control Mode

System function tests and floor cleaning robot movements are performed via remote RC based control application input. The test is carried out on the basis of the robot's navigation movement that is forward, backward, right and left shear and motor pole activation.

Table 1. Test Manual Robot

Button re- mote	Action	Test			
		1st	2st	3st	4st
Forward	Robot	OK	OK	OK	OK
Backward		OK	OK	OK	OK
Right		OK	OK	OK	OK
Left		OK	OK	OK	OK
Turn Right		OK	OK	OK	OK
Turn Left		OK	OK	OK	OK

E2. Automatic Mode

The next mode of the system operation is automatic mode of operation. Under automatic mode of operation, the robot can perform all the operations autonomously without any human support to do the needful.

A map-based robot navigation system consisting of mapping, localization, path planning, and trajectory tracking is implemented on a wheeled robot with a Robot Operating System (ROS) platform. To perform the navigation, the robot is equipped with sensors and controllers that can be applied according to the task.



Figure 8. The movement of the vacuum motors



Figure 9. The movement of the vacuum motors

Map Building

In the previous section, we mentioned the design autonomous BERSAUDARA robots used, as well as configuring environment in which the simulation will take place. On this section will describe the algorithm that used in the process of building maps in order to solve navigation problems on robots autonomy, particularly in localization issues.

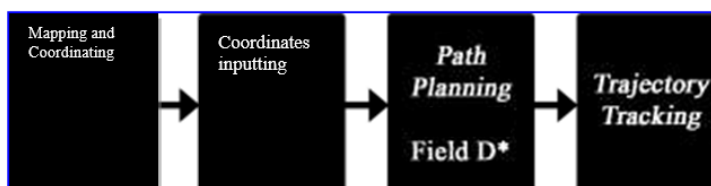

Figure 10. Map-Based Indoor Navigation Process Block Diagram

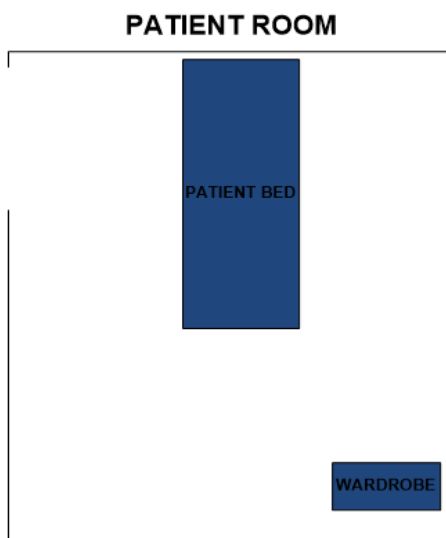

Figure 11. Patient room Maze

Flood Fill Algorithm Rules

1. The space in which the mobile robot moves must be represented by a discrete world, from a matrix of two dimensions. This matrix must have the cells (nodes) of the same robot size, so that it can only reach a node traveling a distance equal to its dimensions.
2. The body of the robot is used as reference to print the location of the other cells in the whole image, which, in the case of Fig. 11, is generated a matrix array of 5x6 cells.
3. Obstacles are in the junctions of the nodes, so there is no one inside a cell. bed patient and wardrobe
4. The Bersaudara robot can only make linear movements on the horizontal and vertical axis. So the solution to a path will correspond to the union of orthogonal lines

The robot will be programmed to follow the node whose value increases, if there is an obstacle, the robot will detect the obstacle in front, the ultrasonic sensor will be placed in front of the robot face.

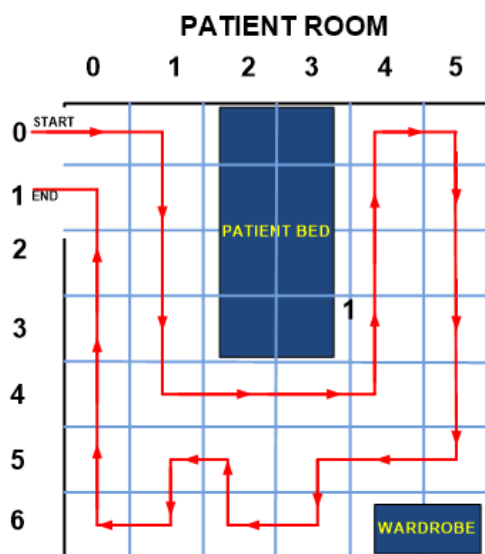

Figure 12. Patient room labyrinth

When the robot is placed back at the starting point, it autonomously navigates towards the destination cell using the optimized path information

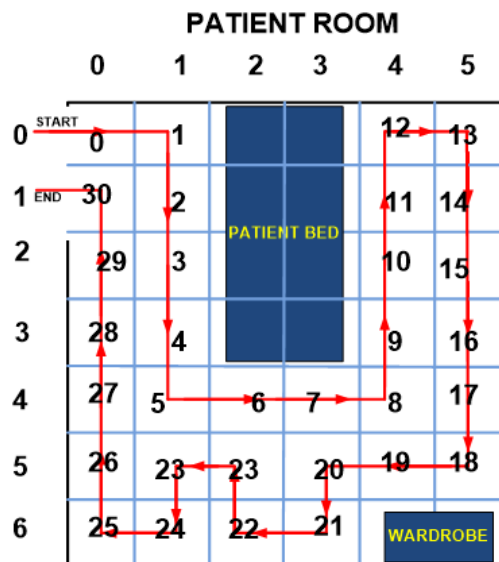

Figure 13. Patient Room plan and movement route robot Bersaudara

After reaching the goal the last flooding occurs and the shortest path linking the starting point with the goal from the mapped part of the maze is determined as shown in Figure 12. The maze flooding is based on the flood fill algorithm which block diagram is shown in Figure 13.

3. Conclusion

The COVID-19 virus is mostly transmitted through droplets and aerosols that stick to the floor of a room and can remain infectious on surfaces at room temperature for several days. Therefore, this robot can be applied in hospitals for COVID-19 patients. The air purifier inside the robot reduces pollutants in the room and improves air quality and is available The UV-C Germicide lamp kills germs, bacteria and viruses trapped in the filter.

The design of the room and air cleaning robot has been successfully created and can function properly. Development of a simple floodfill algorithm that can be quickly implemented regardless of mapping and destination search algorithms can be applied in BERSAUDARA robots.

Future work may include studying larger rooms, the ability to solve the best path in a wider and more complex obstacle. This also needs to be further improved specifications object sensors, such as a wide laser range finder, for better.

Acknowledgements

This work was supported by Universitas Sanata Dharma Yogyakarta.

References

1. Kementerian Kesehatan RI, Direktorat Jenderal Pencegahan dan Pengendalian Penyakit (P2P). (2020). Pedoman Pencegahan dan Pengendalian Coronavirus Disease (COVID-19). J
2. Han Y, Yang H. The transmission and diagnosis of 2019 novel coronavirus infection disease (COVID-19): A Chinese perspective. *J Med Virol.* 2020; published online March 6. DOI: 10.1002/jmv.25749
3. van Doremalen N, Bushmaker T, Morris DH, Holbrook MG, Gamble A, Williamson BN, et al. Aerosol and Surface Stability of SARS-CoV-2 as Compared with SARS-CoV-1. *N Engl J Med.* 2020; published online March 17. DOI: 10.1056/NEJMc2004973
4. Ong SWX, Tan YK, Chia PY, Lee TH, Ng OT, Wong MSY, et al. Air, Surface Environmental, and Personal Protective Equipment Contamination by Severe Acute Respiratory Syndrome Coronavirus 2 (SARS-CoV-2) From a Symptomatic Patient. *JAMA.* 2020; published online March 4. DOI: 10.1001/jama.2020.3227
5. Keputusan menteri kesehatan Republik Indonesia Nomor HK HK.01.07/MENKES/328/2020, tentang panduan pencegahan dan pengendalian corona virus disiese 2019 di tempat kerja perkantoran dan industri dalam mendukung keberlangsungan usaha pada situasi pandemic.
6. Kementerian Riset dan Teknologi. (2020). Katalog Inovasi Karya Peneliti dan Perekayasa Kemenristek/BRIN untuk Mengatasi Pandemi. Jakarta: Kementerian Riset dan Teknologi.