

Received on 2022-08-05, Reviewed on 2022-11-03, Accepted on 2022-11-10, Copy edited on 2023-02-24, Layout edited on 2023-02-25 and Available online on 2023-02-28

Static continuous passive motion machine simulation tacle therapy with SolidWorks

Felix Krisna Aji Nugraha^{1,*}, Antonius Hendro Noviyanto², Baskoro Latu Anurogo³

^{1,3}Mechanical Design Technology, University of Sanata Dharma of, Yogyakarta 55282, Indonesia

²Electromedical Technology, University of Sanata Dharma, Yogyakarta 55282, Indonesia

*Corresponding author: felix@usd.ac.id

Abstract

Patients with joint injuries or after joint surgery are expected to perform the passive and continuous movement to avoid joint stiffness. This passive and continuous movement can be done with the help of a Continuous Passive Motion Machine (CPM machine). CPM machine is a therapeutic tool used to rehabilitate patients with joint injuries or post-joint surgery. In this study, a simulation test of therapeutic equipment for the ankle joint that can be moved rotationally will be carried out. The method that will be used in this research is the Finite Element Analysis (FEA) method to analyze and simulate the strength of the elements used in the design model. The results to be sought in this study are the results of the stress and yield strength of the tool, so that the safety of the tool design will be known. The simulation results using carbon iron get a maximum stress of 3.012×10^5 N/m² and yield strength of 2.20594×10^8 . Based on the results obtained in this study, it can be concluded that the CPM machine design is safe and strong to be realized.

Keywords:

static simulation, continuous passive motion, solid works, stress, yield strength

1 Introduction

Patients with limited movement of the crank joint or post-traumatic joint of the crank joint require a long rest and are needed to make light movements in the crank joint. Such light movements can be helped by tools that can move passively and continuously. So, passive and continuous movement can restore the limitation of motion of the crank joint [1]. A constant Passive Motion (CPM) machine is a therapeutic tool used to assist patients in moving the crank joint after the patient undergoes crank joint surgery [2][3]. The working principle of this therapeutic tool is to carry out passive and continuous movements. This passive and constant movement aims to prevent the patient from experiencing stiffness in the crank joints [4][5]. CPM machine is a medical device that has strict quality control, so it does not pose a danger to patients who use the device.

Tool safety can be determined by performing a tool simulation to assess the level of stress, strain, displacement, and yield strength using solid work software [6][7]. The most widely used method for analyzing elements is the Finite Element Analysis (FEA) method [8]. This FEA method can be used before making a prototype tool.

The study aimed to determine the CPM machine's stress and yield strength of the CPM machine. The stress level in this study

was used to determine the resistance strength of the device to support the load from the patient's legs. While the yield strength in this study is used to analyze the frame strength of the CPM machine design.

2 Methodology

The development of Computer Aided Design (CAD) technology is very helpful in designing a product or machine. The process of creating in manufacturing industries uses a lot of time. An engineer who has experience in using CAD can use various tools/facilities in CAD software in multiple applications in mechanical engineering so that the time spent designing can be done shorter, and productivity and quality can be produced better [9].

2.1 Research methods

The simulation process to analyze strengths uses SolidWorks 2018 software that can simulate the strength of the elements in the designed model [10]. Strength analysis of the design both geometrically and shape using a static load of the foot weight of the patient to be treated.

2.2 Simulation process

The simulation process carried out with the help of SolidWorks software will produce external data that is by the selected material, type of analysis, type of loading, and direction of loading. The resulting output is then compared with the clearance stress of the design and the material used. The flowchart indicates the stages in Fig 1:

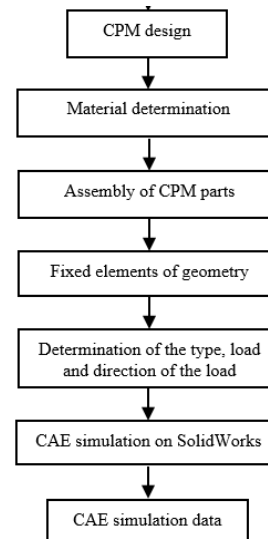

Fig 1. Research flowchart

The CPM machine design plan will be used for hospitals and clinics so that it has criteria in terms of function, economy, and additional safety [11]. Table 1 describes the specifications of the CPM machine design. CPM design for crank joint therapy with material from all elements determined using plain carbon. the specification depicted in table 2 [12].

Table 1. CPM Specifications

No	Specifications	User Restrictions
1	Geometry	Therapeutic dimensions used for 1 leg
2	Performance	Movement CPM machine is rotational motion, with a maximum rotational speed of 5rpm
3	Use	Perfectly seated patient position
4	Material	Carbon steel
5	Displacement	Deflection less than 3 mm
6	Production	Easy in the provision of materials and machining processes

Table 2. Material specifications

Properties	Carbon Iron Material
Yield strength [N/m ²]	220594000 N/m ²
Elastic modulus [MPa]	2.1×10^{11} N/m ²
Poisson's ratio	0,28 N/A
Mass density [kg/m ³]	7800 kg/m ³
Tensile strength [N/m ²]	399826000 N/m ²

This static simulation process aims to find out the strength of the CPM machine against loading. The first stage in this simulation is determining fixtures in the form of fixed geometry [13]. Fixed geometry is a buffer in real conditions when the CPM machine is used. There are 9 pieces of fixed geometry used. Furthermore, the provision of a load or load in the form of legs from the treated patient. Determination of the foot load of patients who will undergo therapy with this CPM machine by 1.5 kg (15 Newton). By using a safety factor of 2, the load will be simulated by 3 Newtons [14]. The load or load is considered a static load which is a compressive load against the surface of the element that supports the patient's foot. After the process, a gravity direction of 9.81m/s^2 is also determined. Next process is the meshing. In FEA, meshing is one of the steps in running a simulation. Meshing aims to divide a component into a continuous geometric shape. the smaller the size of the continuous geometry, the more accurate the meshing of the component model to be simulated. On the CPM machine, the meshing use meshing parameters using a standard mesh with a fine mesh density. At that parameter, the largest mesh size with dimensions of 7.6358318 mm with a tolerance of 0.38179159 mm is seen in fig 2(a) and Fig 2(b)-(d)[15].

3 Result and discussion

The meshing process in the 3-dimensional machine design is seen in fig 3:

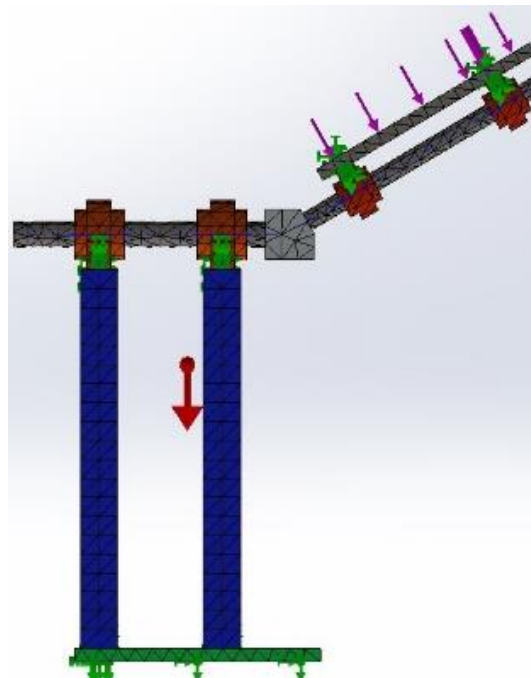
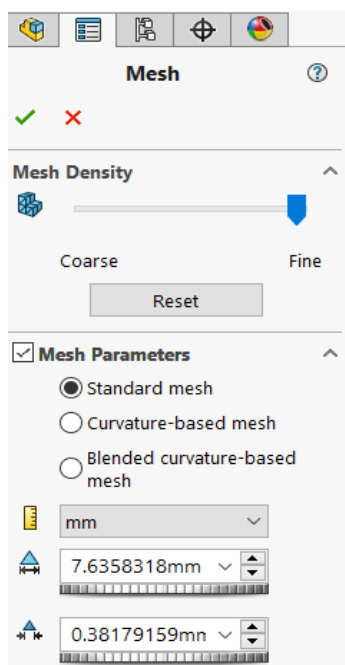
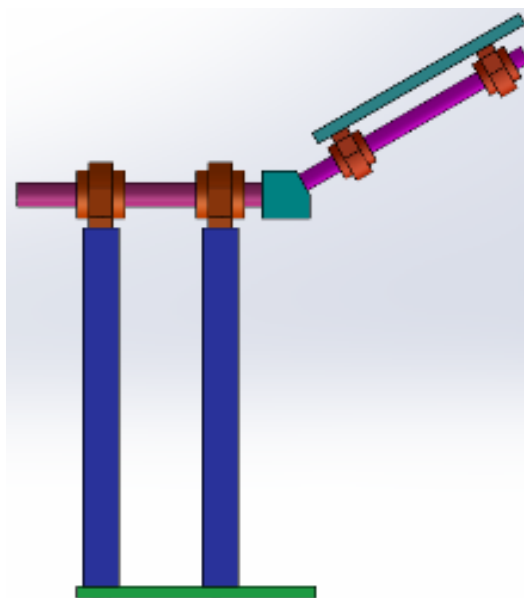

Fig 3. Loading and meshing results on the CPM machine



(a)



(b)

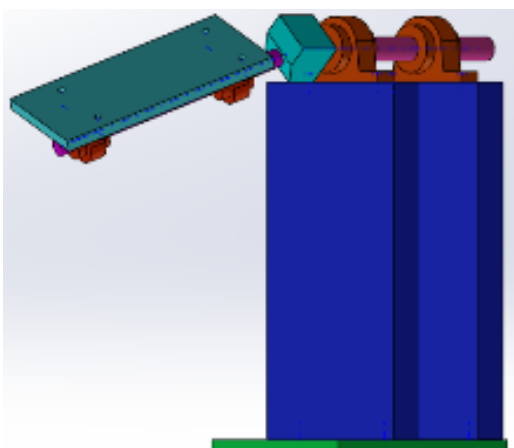

(c)

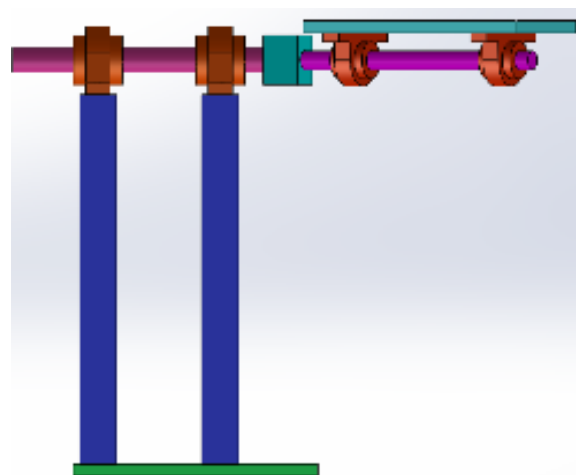

(d)

Fig.2 Meshing and Images (a) Meshing parameter (b) at load position on CPM machine 0° , (c) at load position on CPM machine 45° , and (d) at load position on CPM machine 90°

Using the standard engine from SolidWorks software, meshing that occurs in the CPM machine in table 3.

Table 3. Results of meshing of the CPM machine

No	Mesh information	Detail
1	Total Nodes	103035
2	Total Elements	65779
3	Maximum Aspect Ratio	13.76

The simulation process is based on ankle movements, namely plantarflexion and dorsiflexion [16]. The simulation takes 3 positions of the patient's feet at the time of therapy, namely at 0°, 45°, and 90°. The simulation results on each position with the same load in fig 4-6.

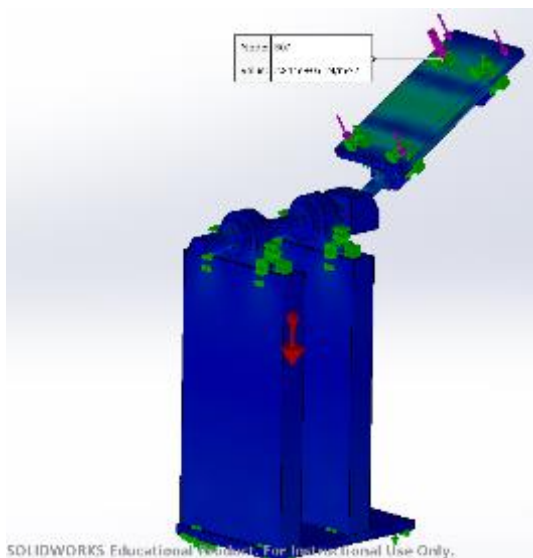

Fig 4. The maximum stress that occurs at a position of 0°

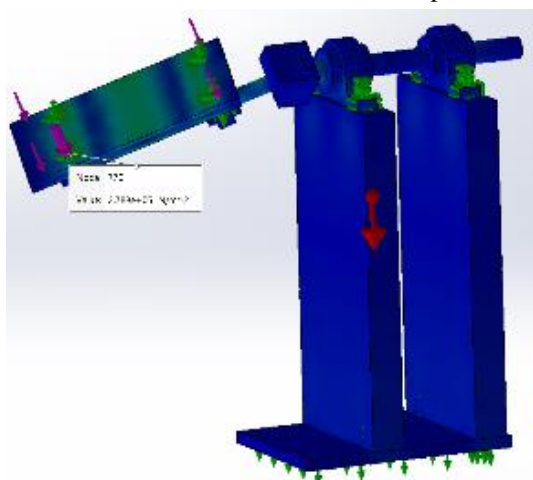

Fig 5. The maximum stress that occurs at position 45°

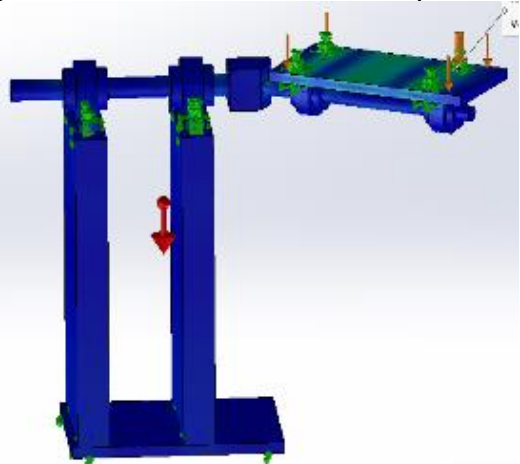

Fig 6. The maximum stress that occurs at the position of 90°

Of the three positions, the results of the calculation for the stress that occurs in the CPM machine can be seen in table 4:

Table 4. Results of stress at each position of the CPM machine

No	Position	Stress Maximum (N/m ²)
1	0°	2.811e+05
2	45°	2.789e+05
3	90°	3.012e+05

From the results of the simulation carried out, the largest stress occurred at the time of position 90° of 3.012x10⁵ N/m². With a yield strength of 2.20594x 10⁸ N/m², while with the maximum stress that occurs the design is still below the yield strength of the selected material.

The motion movement produced on this CPM machine is more complete by producing 360° rotational motion. So that the movement is a combined movement of plantarflexion and dorsiflexion movements, and moves simultaneously between the two movements.

4 Conclusion

From the simulation results of the CPM machine design that uses carbon iron material as a tool for therapy of crank injuries, a maximum stress that occurs is obtained by 3.012x10⁵ N / m² and yield strength of 2.20594x 10⁸. It can be concluded that the design of the CPM machine is safe and strong. In the future, it is possible to modify in terms of dimensions and shapes of the elements in the machine.

References

- [1] A. Konseptual and S. Sumartiningsih, "Cedera Keseleo pada Pergelangan Kaki (Ankle Sprains)," *Juli Disetujui: Juni*, vol. 2, pp. 2088–6802, 2012. [Online]. Available: <http://journal.unnes.ac.id/nju/index.php/miki>
- [2] S. Miyaguchi, K. Nojiri, N. Matsunaga, and S. Kawaji, "On Effective Movement in CPM for Shoulder Joint," in *IEEE International Conference on System, Man and Cybernetics*, 2008.
- [3] S. Miyaguchi, N. Matsunaga, K. Nojiri, and S. Kawaji, "Impedance control of CPM device with flex-/extension and pro-/supination of upper limbs," *IEEE/ASME Int. Conf. Adv. Intell. Mechatronics, AIM*, 2007, doi: 10.1109/AIM.2007.4412449.
- [4] A. H. Noviyanto, L. D. Septilianingtyas, and D. Rahmawati, "Design of a continuous passive motion (CPM) machine for wrist joint therapy," *J. Robot. Control*, vol. 2, no. 4, pp. 311–315, 2021, doi: 10.18196/jrc.2498.
- [5] A. H. Noviyanto, "Saving the Moving Position on the Continuous Passive Motion Machine for Rehabilitation of Shoulder Joints," *Int. J. Appl. Sci. Smart Technol.*, vol. 01, no. 02, pp. 121–128, 2019, doi: 10.24071/ijasst.v1i2.1921.
- [6] W. D. Callister Jr and D. G. Rethwisch, *Materials Science and Engineering - An Introduction 10th Edition*. 2018.
- [7] P. Kurowski, "Engineering Analysis with SolidWorks," p. 5, 2013, [Online]. Available: https://books.google.es/books?hl=es&lr=&id=rAKzqT4edh4C&oi=fnd&pg=PA1&dq=solidworks+&ots=5HpruoEYok&sig=kP_jTmAEDFGEDdYz4fbi812YiE#v=onepage&q&f=true
- [8] Fahd Riyal Pris, Budhi M Suyitno, and Amin Suhadi, "Analisis Kekuatan Velg Aluminium Alloy 17 Inc Dari Berbagai Desain Menggunakan Metode Finite Element Analysis (Fea).," *Teknobiz J. Ilm. Progr. Stud. Magister Tek. Mesin*, vol. 9, no. 2, pp. 33–39, 2019, doi: 10.35814/teknobiz.v9i2.558.
- [9] F. K. A. Nugraha and A. H. Noviyanto, "Spur Gears Transmission Analysis on Countinuous Passive Motion Machine Design for Shoulder Joint," *Int. J. Appl. Sci. Smart*

- [10] N. A. Puspitasari, Marsono, and M. P. Nugraha, "Simulasi Stress Analysis Pembebanan Statis Dengan Bantuan Software SolidWorks Pada Hasil Perancangan Ladder Frame Chassis Mobil Listrik Menggunakan Material AISI 4340," 2021.
- [11] R. Trochimczuk, T. Kuźmierowski, and P. Anchimiuk, "Study of CPM Device used for rehabilitation and effective pain management following knee alloplasty," *Int. J. Appl. Mech. Eng.*, vol. 22, no. 1, pp. 241–251, 2017, doi: 10.1515/ijame-2017-0014.
- [12] R. S. Khurmi and J. K. Gupta, *Machine Design*. New Delhi: Eurasia Publishing House, 2005.
- [13] J. R. Steffen and S. S. Nudehi, *Analysis of Machine Elements Using SolidWorks Simulation 2017*. Kansas: SDC Publishing, 2017.
- [14] R. Zhao, M. Vahora, and J. Li, "Computer Aided Artificial Ankle Joints Design," no. August, 2018, doi: 10.17148/IARJSET.2018.5414.
- [15] G. Verma and M. Weber, *SolidWorks Simulation 2017 Black Book*. New Delhi: CADCAMCAE WORKS, 2016.
- [16] A. Alipour and M. J. Mahjoob, "A rehabilitation robot for continuous passive motion of foot inversion-eversion," *4th RSI Int. Conf. Robot. Mechatronics, ICRoM 2016*, pp. 349–354, 2017, doi: 10.1109/ICRoM.2016.7886763.