



Received on 2022-11-02, Reviewed on 2022-12-15, Accepted on 2022-12-15, Copy edited on 2023-01-17, Layout edited on 2023-0-20 and Available online on 2023-02-28

Dove Tail Interlocking Tensile Stress Analysis Comparison of ABS And PLA Material in SolidWorks Simulation

Felix Krisna Aji Nugraha*, Bertha Bintari W

Faculty of Vocation, University of Sanata Dharma, Yogyakarta,
Indonesia

*Corresponding Author: felix@usd.ac.id

Abstract

The Tensile Test Method on PLA material for product printing using a 3D printer will recommend the dove tail design as an interlocking part. The result of the design of the dove tail type as an interlocking joint part is tested for the most optimal tensile strength. In this paper, consideration for the dove tail design used in material testing and will be printed using a 3D printer is in terms of technical ease of printing and technical testing of its physical form so that it can be gripped using a tensile test tool such as the Universal Tensile Machine (UTM). The dove tail design is designed with a scale representative size that meets the requirements of the standard clamp size of the test tool. Tensile force testing simulation using SolidWorks software will be used as a pre-tensile test analysis before being implemented by UTM. The results obtained are the deformation that is occurring, such as the PLA material having a higher deflection of 7,567 mm and the ABS material having a deflection of 1,897 mm. The strain on interlocking is 0.1081 for ABS material and 0.3988 for PLA material.

Keywords:

PLA, ABS, tensile test, interlocking, simulation

1 Introduction

With 3D printing technology, the freedom of design is limitless. Additive Manufacturing allows the use of completely new designs, such as interlocking tools or parts. With 3D printing using PLA (Polylactide Acid) and ABS (Acrylonitrile Butadiene Styrene) materials, they still have the flexibility of shape, especially for product prototype designs.

As a fast prototyping, 3D printers have drawbacks in terms of the maximum size that can be printed. Therefore a large product, exceeding the maximum size of beds 3D printers, is made by dividing the object into several parts that are assembled or assembled. These parts of the object certainly require thought and design of the hook, lock for the connection of product parts.

The ability of 3D printing is to be able to easily design interlocking parts this because of the high accuracy of 3D printing. As a result of the mold to be assembled, the design must also have a size tolerance, and because there are aspects of material shrinkage, this tolerance value must be considered carefully. Consideration of size tolerances must be used, then the interlocking and jointing are snug and matched. Therefore, a good design is needed to ensure which is the interlocking parts are installed securely and snugly. In

addition, there are several interlocking joint parts that have a specific design due to their functional demands.

This research aims to find the determining parameters in simulation experiments using SolidWorks software that are closest to the results of tensile testing that will be carried out in reality. By finding the most influential parameters using this simulation, it will optimize the determination and application of parameters to the original physical specimen.

The problem in this case is to determine the maximum tensile force that a dovetail-shaped interlocking joint can withstand. What are the parameters that will affect the tensile strength of the joint? The interlocking joints need to be tested for tensile strength up to the maximum size so that dovetail applications can be properly applied to designs that exceed the size of the 3D printer's print bed. The type of interlocking that the tensile test will simulate is the Dovetail interlocking. A dovetail interlocking is a type of interlocking joint that is very stable but easy to remove. Dovetail named by the shape of the connector, it is best used on flat and thin objects.

Dovetail joints provide a lot of contact between the two parts being joined. The resulting increase in friction makes dovetail joints so difficult to break that dovetail joints are almost impossible to separate by tension forces. The increased contact area is also great for applying adhesives [1].

In this test the interlocking joint part design uses PLA and ABS plastic materials. This interlocking joint part is used for casing design, or product enclosures made of plastic. The design of the interlocking joint part has a locking system that is custom-made to the locking needs. Laily Noor Ikhsanto tested the strength and flexibility of PLA material compared to ABS [2]. ABS filament is stronger than PLA filament, but PLA filament is more flexible than ABS filament. ABS is stronger than PLA because from the bending test results to achieve a displacement of 3 mm, ABS filament is able to withstand heavier loads than PLA filament. PLA is more pliable than ABS in bending tests. Therefore, this interlocking part test will compare the PLA material with ABS as the material for interlocking.

In a study did by Vasile Ermolai et al, that the bonding of the layers determines the surface contact at the interlacing [3]. A comparison of PLA with ABS conducted by Koray found that the best mechanical properties were of the specimens made of PLA material [4]. ABS material has the highest strain, and the analysis results show that it is the lowest strength compared to PLA material. However, its properties depend on the reinforcing agent added to the binder.

Previous research on tensile strength testing has been carried out by Pratama on products with ASTM standard forms [5]. Shrinkage testing and tensile testing were conducted to determine the material properties. The study concluded that the optimization of 3d printing process parameters on the tensile strength of PLA + filament material using the taguchi method; for example the most influential factors on Esun PLA + filament are nozzle temperature, layer thickness, printing speed, orientation and cooling speed.

The orientation position of the printed object will affect product quality and different times. Sutanto and Lubis conducted research to determine the process time and surface conditions of products printed using 3D printing [6].

In the research by Sobron Lubis studied the effect of determining the position of the printing orientation of products printed in vertical and horizontal positions. Test objects with the form of ASTM D638 Tensile test objects are tested for the tensile strength of PLA and ABS materials [7].

In addition to the orientation position of the printing process, research conducted by Gita concluded that the strength value of the specimen using 3D printing technology requires optimal parameter settings on the 3D printer [8]. Testing was carried out by testing PLA material specimens measured by the value of tensile strength

of the resulting product. The test is done by measuring the amount of voltage that occurs during the tensile test [9].

Finali's research examines the tensile test of different 3D printed specimen pattern variations [10]. The test results showed that the products resulting from the three-dimensional printing process carried out on the rectilinear, triangular, honeycomb pattern variations, the highest tensile strength was owned by specimens with a triangular pattern, with an average value of tensile strength of 29.01 N/mm², with the standard D638 tensile test specimen.

Zamheri applies printed products in the form of teeth that are analyzed for material shrinkage after printing. Zamheri's research aims to determine the shrinkage of filament material of human denture products using different parameters.

Panjaitan conducted research on the effect of speed, temperature and infill on the quality and roughness of 3D printing prints. From his research, it was concluded that all printing products have rough surface properties. From the influence of printing speed and nozzle temperature, the higher and lower percentage of infill produces better product quality and lower / smoother roughness [12].

From the above studies, no one has discussed how interlocking joint parts with various types are tested for tensile strength. So this research is important because size limitations in the 3D printing process reduce the flexibility of design and size freedom, which certainly requires interlocking joint parts to make a product that is intact, strong and can be used as a large product casing design solution.

A product that is fragmented into several parts requires interlocking joint parts to build a complete product. The breakdown of the part is referred to as a module that has a certain type, size and shape.

Suci Sukmawati states as the forming of a product which has a module (modular) needs to recognize the components of the module[13]. A module consists of several basic parts of its formation, such as: a. The base of the outer module b. The inside c. Connectors or holes for interlocking with other modules d. Tab or the edge of the module.

For the joint molding process, Zapciu concluded from his research that the special orientation of the joint axis has advantages and disadvantages, the optimal solution being the consideration between joint strength and precision[14]. In revolute joints, surface quality is important and there should be no defects caused by functional extruder transitions.

2 Methodology

To determine the joint strength of the interlocking is to test using a tensile test [15]. Stress is the force per unit area on the material as a reaction to the material exposed to the action load. Where this stress is used by the object to keep this object in its original shape. Strain is a change in the shape of a material when it is exposed to a load. These changes can be in the form of changes in length, shortening, shrinking and so on. Displacement or displacement is the change of material from the starting point to the end point after being exposed to a load[16]

Tensile testing is a test of the mechanical properties of materials such as tensile strength, yield strength and ductility. The mechanical properties of a material in the tensile test are obtained from the stress and strain curves of the tensile test results[17] [18]. The graphs and specimen dimensions show the approximate values for tensile strength, yield strength, Young's modulus, elongation, area reduction, ductility modulus, strength constant (K), and exponential strain (n). The principle of tensile testing is a tensile test of a test object by applying a uniaxial force (one axis) in such a way that the test object or material is deformed or elongated until the test object will fail. The increase in force and increase in strain is the initial data output from the tensile test. The graph shows the results of the force data plot and the increase in sample length until the sample is broken[19].

In materials science and engineering, the von Mises yield criterion can also be formulated in terms of von Mises stress or equivalent tensile stress, σ_v , the scalar stress value can be calculated from the stress tensor. In this case, the material is said to start yielding when the von Mises stress reaches a critical value known as yield strength. Von Mises stress is used to predict the yield level of the material under loading conditions from the results of simple uniaxial tensile tests.[20]

For specimen testing, the specimen design uses a dovetail interlocking design. This test does not use ASTM standards because the type of material to be applied is already known and is a test of interlocking so it uses an interlocking design. Specimen thickness refers to Specimen geometry used for tensile tests (ISO 527 -type 1A) which is 5 mm of the thickness.

The design begins with drawing interlocking objects and determining ABS and PLA materials using SolidWorks software. Width, length, and thickness were tried with several combinations. Determination of size based on the provisions for ease of gripping when tested for tensile forces with UTM. In stress analysis using drawing software there are several things that need to be considered in modeling, determining styles and constraints[21]

Determination of the shape and type of interlocking based on several considerations. In this test, the design chosen was dove tail with consideration of the ease of printing using a 3D printer and technical gripping on the UTM test equipment, which affected the design to the alignment of the direction of the force.

The ease of printing on the dove tail design because this interlocking design does not require deep holes which will be difficult to clean because printing using a 3D printer requires support.

Testing using simulation in addition to determining the direction of the force, it is also necessary to make adjustments to the actual material. In the material library system in the software, PLA and ABS materials have the material properties listed in table 1.

Tabel 1. Properties of material PLA dan ABS

Property	PLA value	ABS value	unit
Elastic Modulus	480000000	2000000000	N/m ²
Poisson's Ratio	0.35	0.394	N/A
Shear Modulus	318900000	318900000	N/m ²
Mass Density	1400	1020	kg/m ³
Tensile Strength	30000000	30000000	N/m ²
Compressive Strength			N/m ²
Yield Strength	6000000	351633	N/m ²
Thermal Expansion Coefficient			/K
Thermal Conductivity	0.2256	0.2256	W/m.K
Specific Heat	1386	1386	J/kg.K

The analysis simulation in this software uses the static simulation feature. This software simulation emphasizes methods that reduce costs and apply software reliability, especially in control applications. Thus software failure can eliminate the possibility of injuring people or damaging equipment [22].

This simulation illustrates whether objects with selected dimensions, shapes and materials are able to accept a predetermined load or force. Determination of stress analysis when using a tensile test condition approach is actually material, constraints, load, contacts, and mesh.[23]. However, by using SolidWorks simulation, the selection of material types is used so that the simulated samples have the same physical and mechanical properties as PLA and ABS filament materials. In this study using a static simulation so that the results of this simulation in the form of data stress, strain, displacement.

2.1 Simulation settings

Stress Analysis simulation is carried out to obtain the results of static loading in the form of σ (stress) and SF (Safety Factor) and δ

(deflection), this is done to determine the success of the design that has been made.[18] Deflection or deflection is the deformation of the shaft in the y direction due to the normal load on the shaft or beam. Shaft deformation is described by the deflection of the shaft from the position before loading. Based on the principle of superposition force, not only simple or complex forces, all loads can be decomposed into several simple loads under conditions of small deformation [24]. In this simulation process, several stages are carried out, the simulation steps after making the design and determining the used material

2.1.1 Defining material in SolidWorks software

The material applied is ABS and PLA with a predetermined design. The dimensions and shape of the interlocking can be seen in Fig. 1 and Fig. 2.

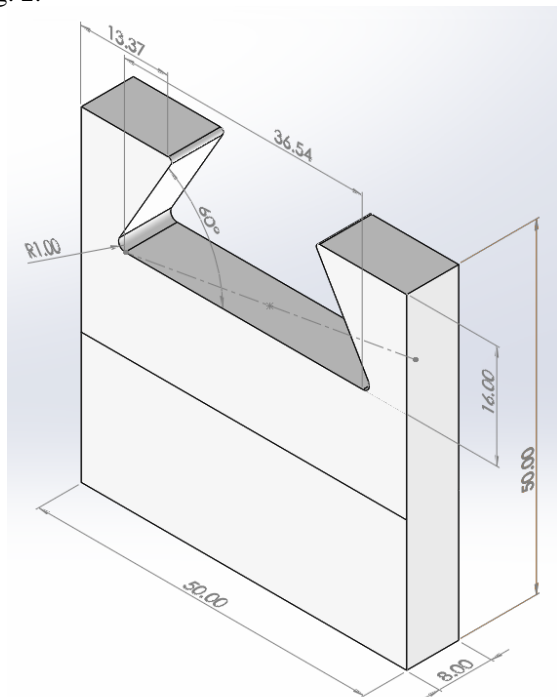

Fig. 1. Dimension of dove tail female

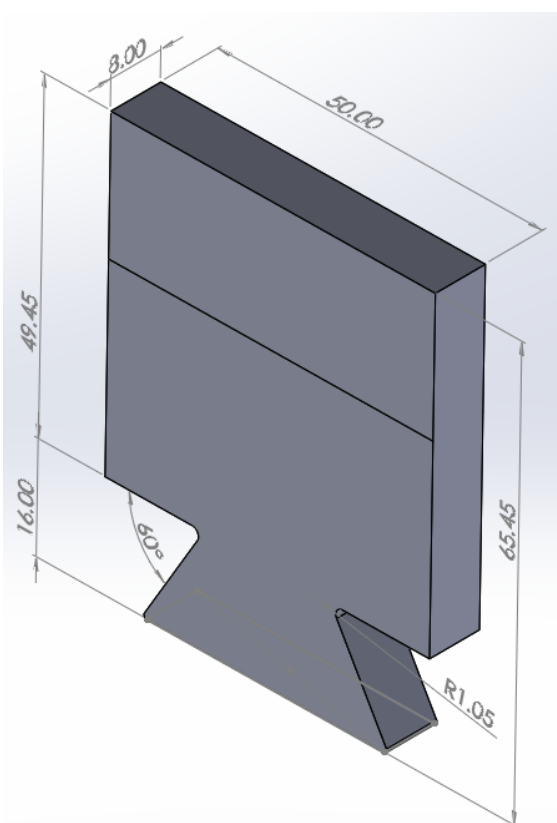

Fig. 2. Dimension of dove tail male

Fig. 3 and fig. 4 are the specifications for the PLA and ABS materials in the SolidWorks software.

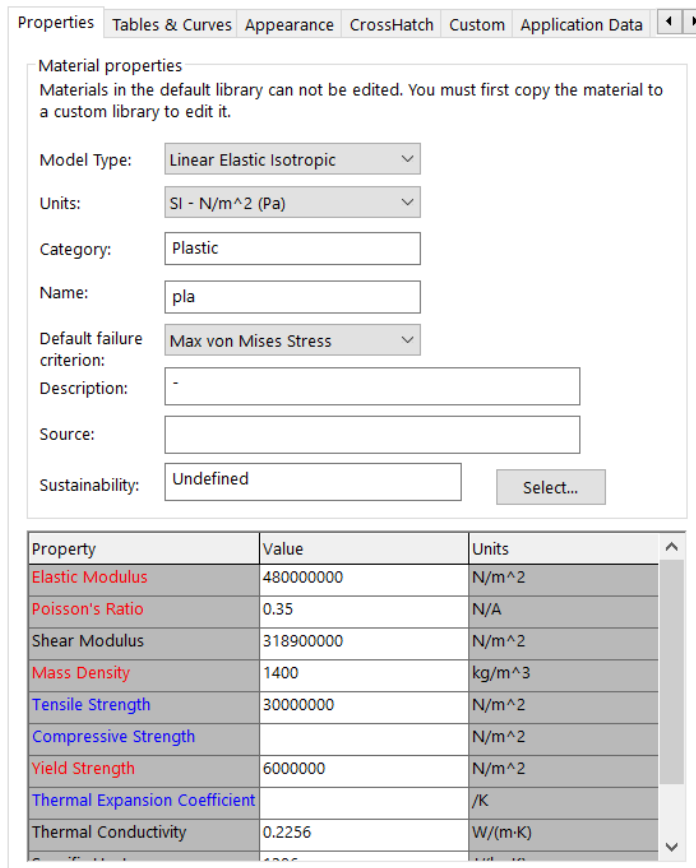

Fig. 3. PLA material material specifications

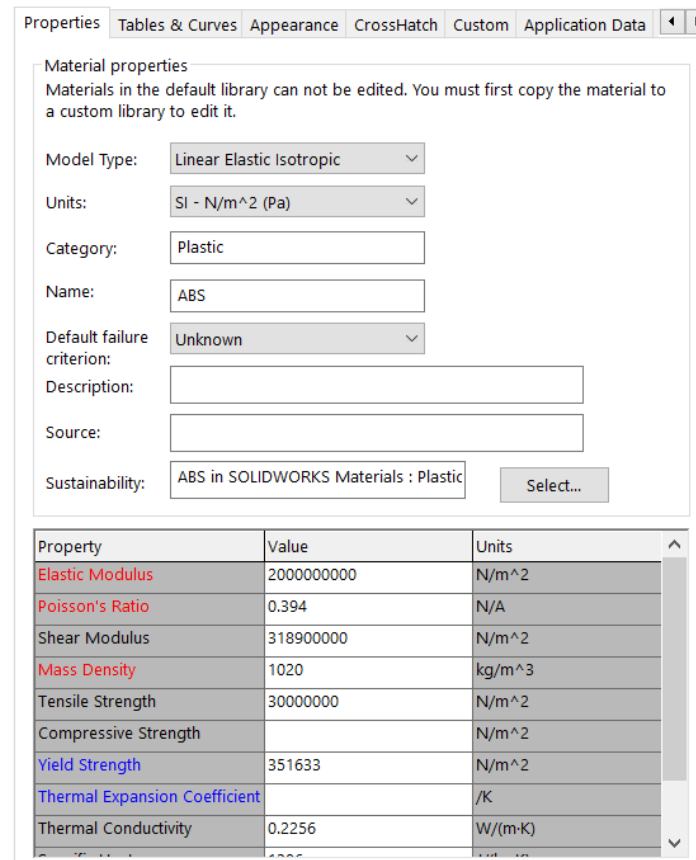

Fig. 4. PLA material material specifications

2.1.2 Define fixtures

The second marks the pedestal on the dove tail interlocking. The support of the part that does not move in translation and rotation in the direction of the x, y, and z axes is given a fixed geometry fixture. In fixed geometry, it can be seen in Fig. 5.

2.1.3 3. External Load

The load is given to the external load fixture. External load is given at 5000N in the direction away from the assembly plane of 2 interlocking dove tail parts.

We assume the direction away from the assembly plane meeting as the load or tensile force exerted on the object being tested. The parts tested and the direction of the tensile loading (external load) are shown in Fig. 6.

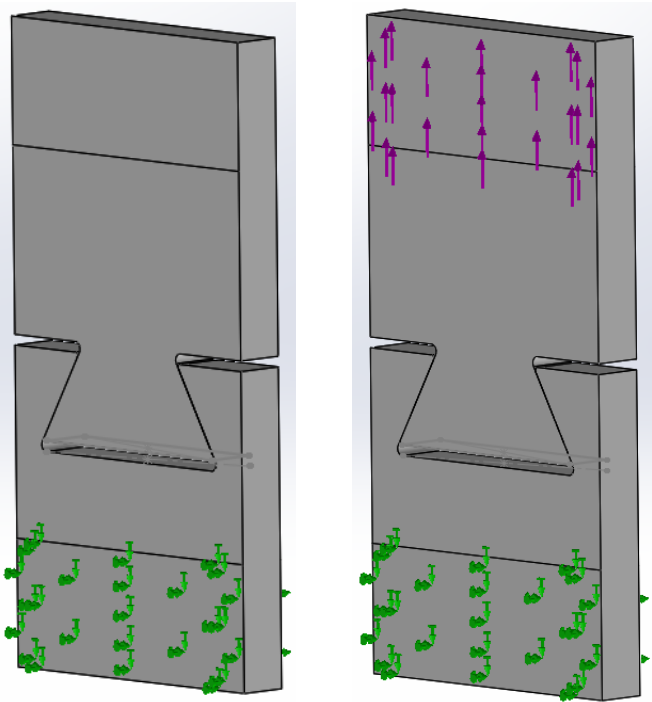

Fig. 5. Position of fixed geometry in simulation

Fig. 6. The external load position and the direction of the working external load

2.1.4 Mesh

Meshing is the division of one or more parts into elements and nodes that are used in mathematical analysis. The principle of FEM is to divide the object model into many small cells of simple shapes, which are used to model the object's geometry as accurately as possible. These tiny cells are called Finite Elements (FE) or simple elements. These cells are connected to each other at points called nodes. The process of transforming an object model into an FE model is called meshing, and it is an important step in the FE workflow. SolidWorks software is able to formulate a number of algebraic equations by themselves, uniting them in one matrix equation through the relationship between elements, material properties of objects, restraints and loads. The solution of the resulting matrix equation governs the behavior of each FE and consequently relates to the whole body. The final result provides different data for stress, displacement, strain, temperature, velocity, acceleration, etc. for each FE. Therefore, the accuracy of the mesh greatly affects the accuracy of the final solution [25]. By using the SolidWorks software the meshing process can be done automatically or by using the largest and smallest element sizes as specified (Analysis of Machine Elements Using SolidWorks Simulation 2017). The accuracy of numerical calculations is highly dependent on density and quality the resulting "finite element" mesh. So accuracy is needed in the manufacture of mesh and for evaluating its quality. [26]. In the process of this research meshing using Curvature based mesh as shown in the picture. Curvature based mesh divides the parts into triangular parts by analyzing the assembled parts according to the shape of the complex parts. The division of the meshing size is carried out as shown in Fig. 7.

In this simulation, the meshing in SolidWorks software uses h-adaptive and p-adaptive meshing. The use of adaptive meshing aims

to refine meshing and improve simulation results. The h-adaptive setting aims to automatically refine the mesh size on parts with a certain area, while the p-adaptive automatically adjusts the order of the polynomial mesh to increase the accuracy of the mesh. The h-adaptive and p-adaptive settings are shown in Figs. 7a and 7b.

Static

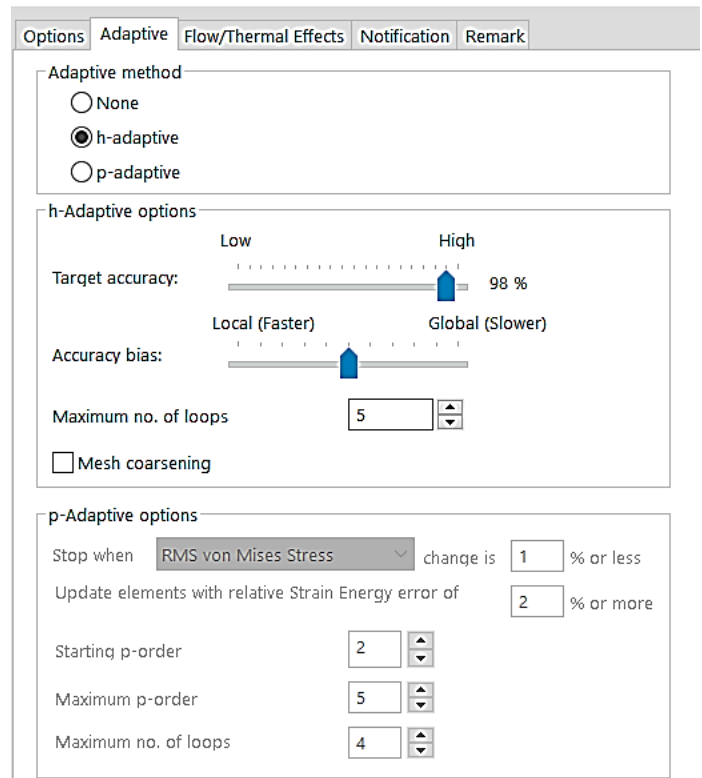

(a)

Static

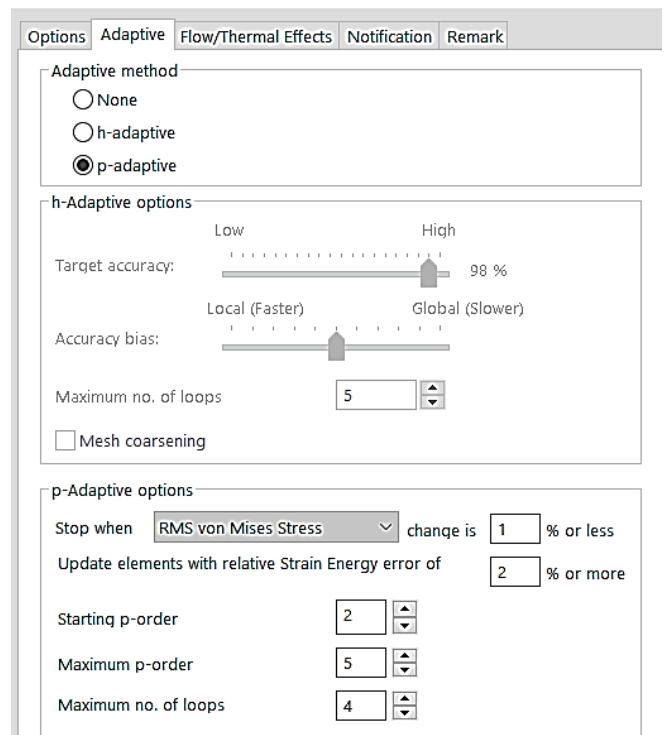

(b)

Fig. 7 Mesh parameter. (a) h-adaptive, and (b) p-adaptive

The mesh element is in the form of an isosceles triangle with the largest side dimensions being 6.81670214 mm and the smallest triangular side dimensions being 1.36334043 mm. From the results of meshing based on curvature-based meshing obtained 5294 elements and 9104 nodes. Figure 8 shows the meshing generated by the SolidWorks.

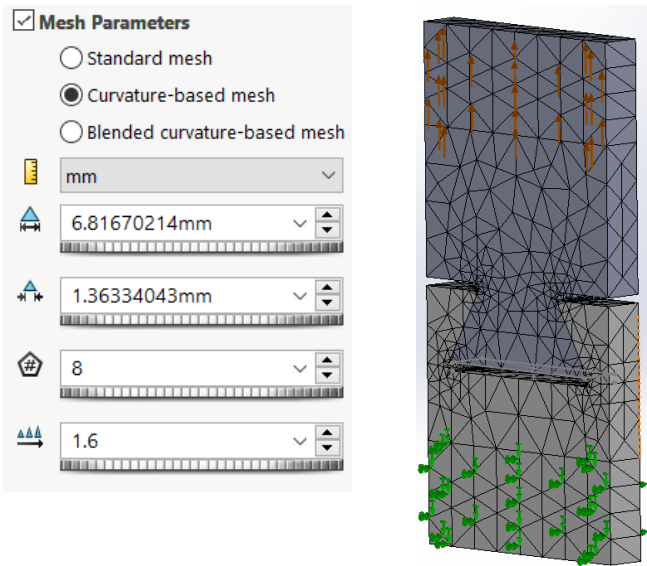

Fig. Meshing (a). Mesh parameters, and (b) Meshing on the specimen

2.2 The Material Simulation test

2.2.1 ABS material simulation test

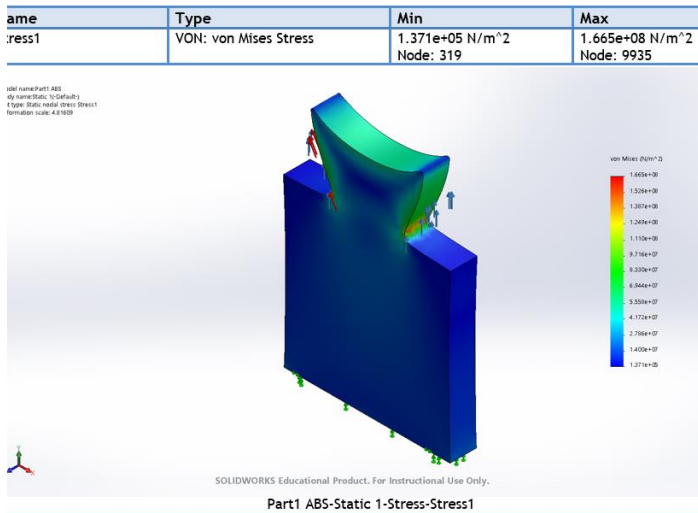

Fig. 9. Maximum stress on dove tail male

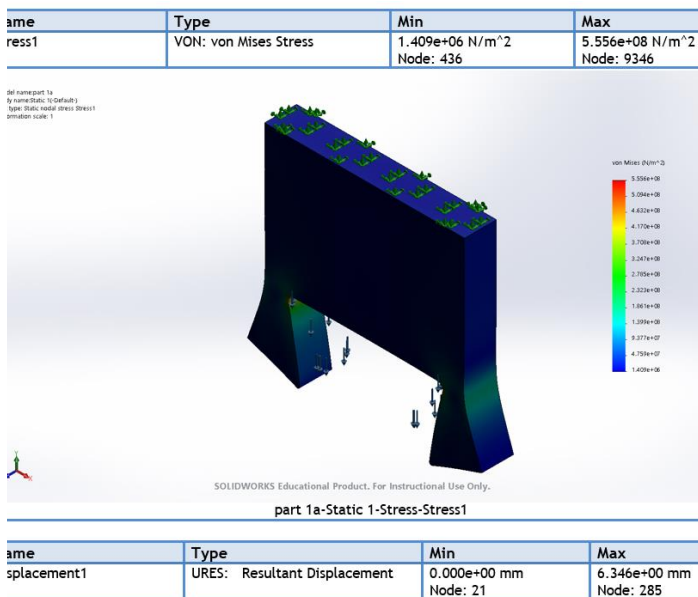

Fig. 10. Maximum stress on dove tail female

From the stress simulation results, each load is safe with a loading of 5000 N, with the maximum stress that occurs.

2.2.2 PLA material simulation test

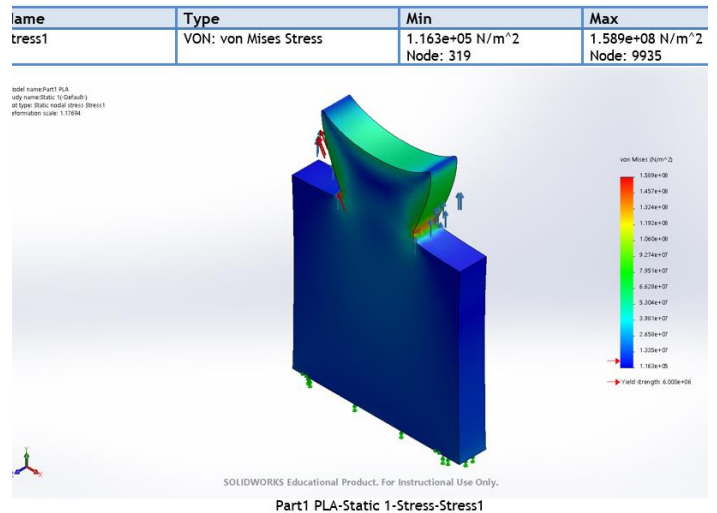

Fig. 11. Maximum stress on dove tail male

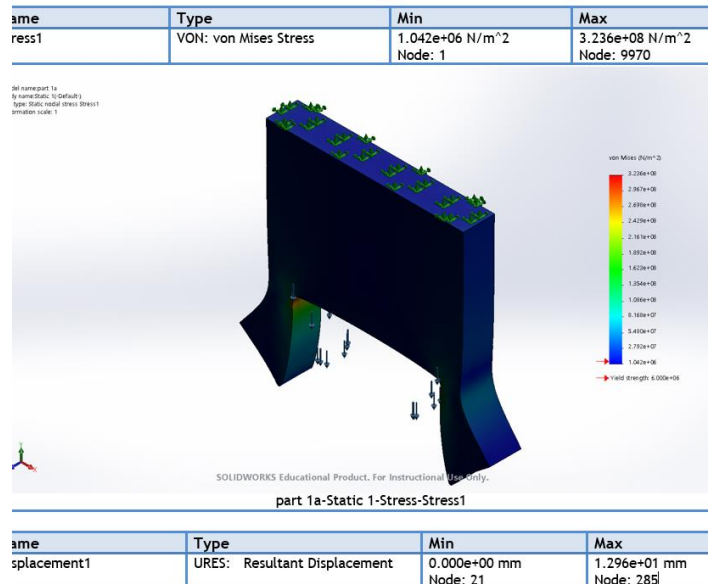

Fig. 12. Maximum stress on dove tail female

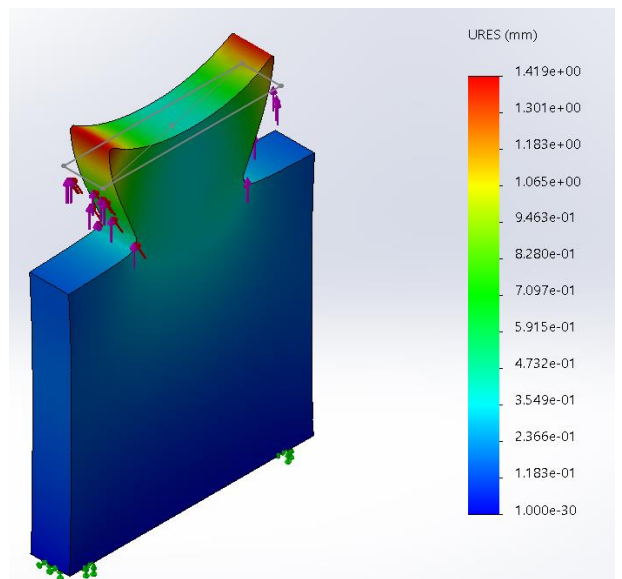

Figure 13. deflection of the dove tail male

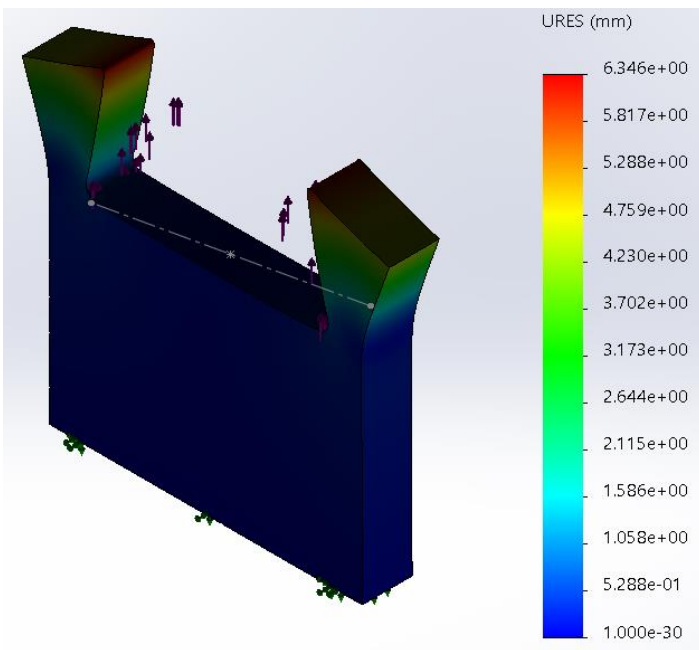

Figure 14. deflection of the dove tail female

The stress analysis simulation process with static loading aims to determine the resistance of the interlocking design that has been made to the load. After doing 2D and 3D modeling using SolidWorks software, proceed with the simulation process using ABS and PLA materials. So that the results are obtained in the form of maximum stress that occurs in an area with a small area at the loading points, the connection section, it can be seen from the simulation results that there is a color change from dark blue to green to yellow which indicates a maximum stress concentration in the interlocking contact area can be seen. in Fig. 11 and Fig. 12. Then the results of the deflection that occur in the interlocking dove tail are also shown by changes in shape that occur in the form of deflection in the opposite direction on the positive axis can be seen in Fig. 13 and Fig. 14. The results of the stress analysis simulation with static loading the last is the value of the safety factor in the interlocking design by looking at the minimum value obtained can be seen in Figs. 15 and 16.

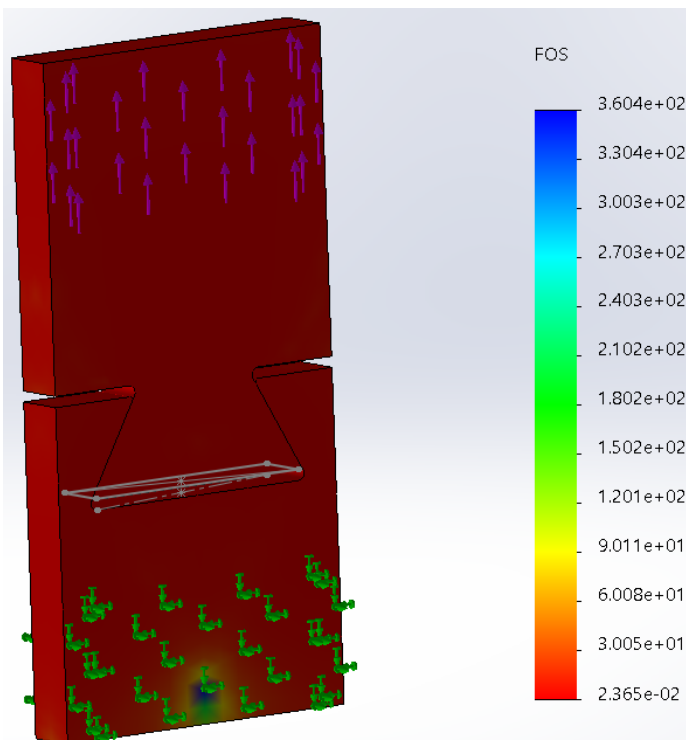

Fig. 15. Safety factor dove tail material PLA

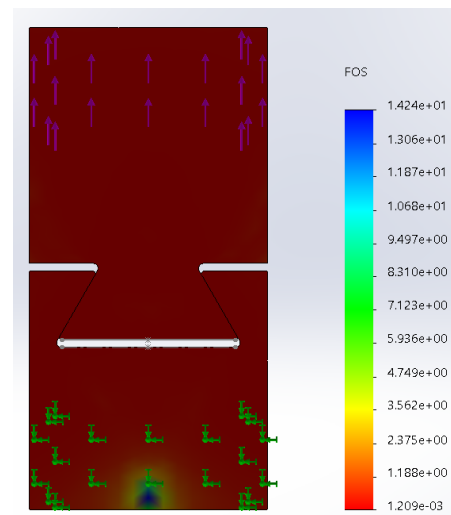

Fig. 16. Safety factor dove tail material ABS

3. Result and Discussion

The static simulation process shows the resistance of the design made with the given load on the design. Figs. 13 and 14 show the stress concentration that occurs in the design, the change in the amount of concentration that occurs in the design is shown in blue which indicates the minimum stress concentration changes to red. which is the maximum stress. From the diagram shown in Figure 19, the maximum stress that occurs in the simulation is $2,909 \times 10^8$ N/m² for ABS, while the PLA material is $2,537 \times 10^8$ N/m² which occurs in the fillet surface area of the dove tail profile.

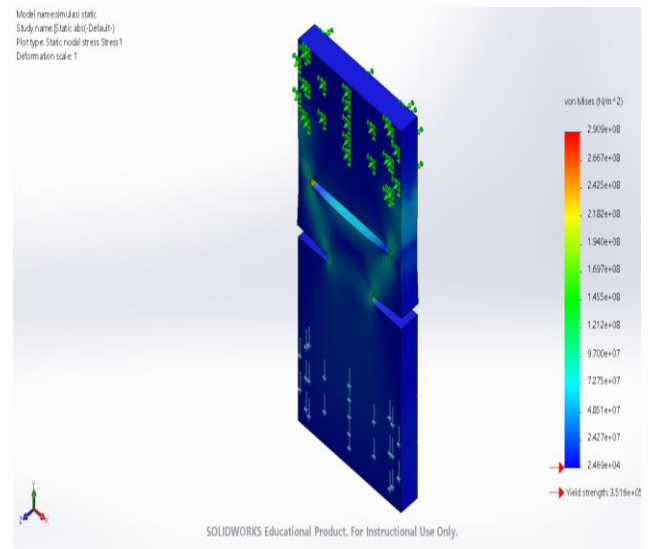

Fig. 17. Maximum stress on dove tail material PLA

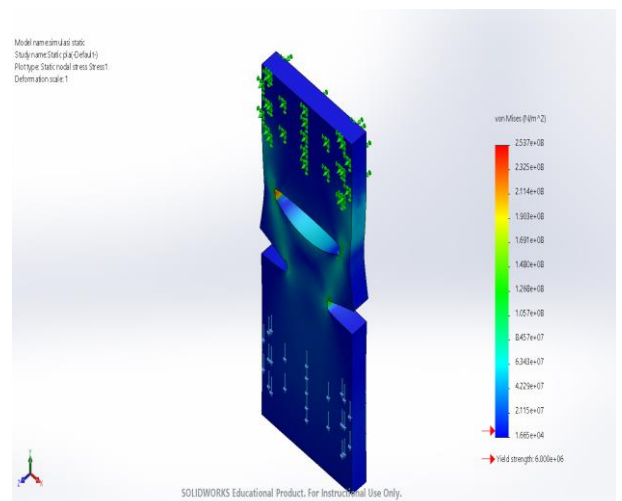

Fig. 18. Maximum stress on dove tail material ABS

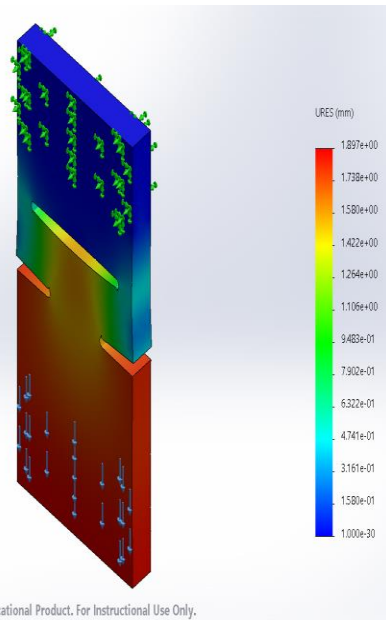

Fig. 19. deflection on dove tail material ABS

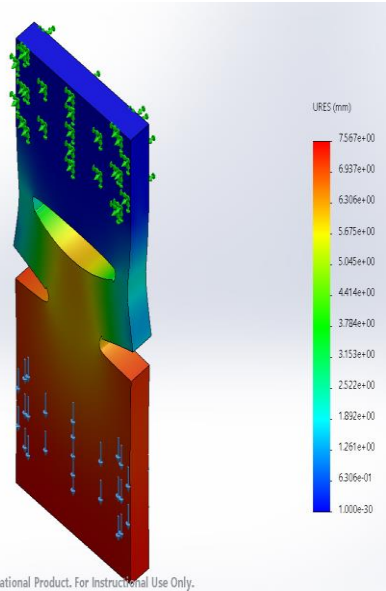

Fig. 20. deflection on dove tail material PLA

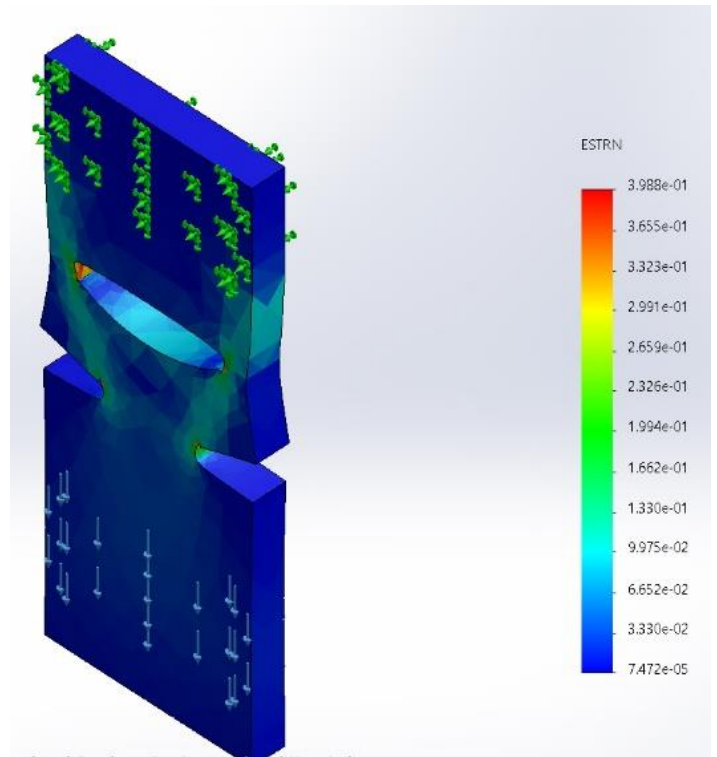

Fig. 22. Strain in PLA dove tail material

The deflection that occurs in the design occurs in accordance with the Y axis or in the direction of the given load. In the picture below is a deflection of the simulation that occurs. The graph in the figure shows the minimum deflection in blue and the maximum deflection occurs in red. Strain is the result of the ratio of the change in length to the initial length of an object under stress. Strain simulation results. From the figure, it can be seen that the simulated ABS and PLA materials are as shown in Table 2:

Table 2. of Stress Force Data

Materials and results	ABS		PLA	
	Minimum	Maximum	Minimum	Maximum
Stress (von Mises Stress)	2.469e+04 N/m ²	2.909e+08 N/m ²	1.665e+04 N/m ²	2.537e+08 N/m ²
Deflection	0.000e+00 mm	1.897e+00 mm	0.000e+00 mm	7.567e+00 mm
Strain	2.538e-05	1.081e-01	7.472e-05	3.988e-01

In the interlocking tensile test simulation of ABS material with a tensile load of 5000N, the maximum stress that occurs is 2,909e+08 N/m², while the Yeild strength of ABS material is 351633N/m². In the interlocking dove tail of PLA material, the maximum stress that occurs is 2.537e+08 N/m² with a yield strength of 6000000 N/m². Von Mises stress shows the yield strength of a material. With the stress that occurs in each material is greater than the yield strength, the material undergoes plastic deformation. The deformation that occurs can be seen from the table that the PLA material experienced a higher deflection of 7,567 mm and the ABS material experienced a deflection of 1,897 mm. The strain that occurs in the interlocking dove tail for ABS material is 0.1081 and for PLA material is 0.3988. This shows that the increase in length from the PLA material design is greater than the ABS material. Simulation results that have been carried out on each result, the interlocking with ABS and PLA materials is not strong or unsafe.

3 Conclusion

Based on the simulation of the interlocking dove tail design with ABS and PLA materials, it can be concluded:

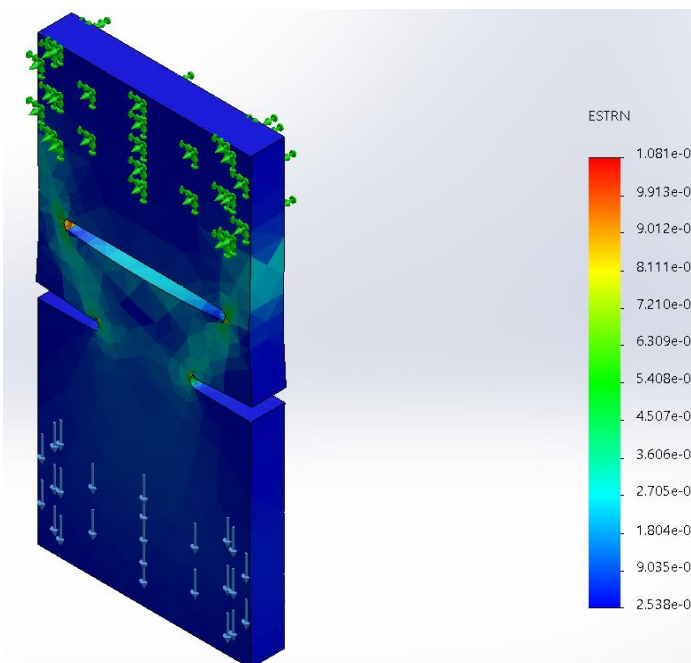

Fig. 21. Strain in ABS . dove tail material

1. Simulation results with von Mises Stress analysis show that the maximum stress for ABS material is $2,909e+08$ N/m², for PLA material it is $2,537e+08$ N/m²
2. Simulation results with deflection obtained for ABS material of 1,897 mm, for PLA material of 7,567 mm
3. Simulation results with strain obtained for ABS material of 0.1081, for PLA material of 0.3988
4. From the simulation results the safety factor for ABS material is 0.0012 while PLA material is 0.024, thus the interlocking design with ABS and PLA materials is not strong enough to be exposed to a load of 5000N.

The safety factor for abs is 0.0012, and pla is 0.024. with the 3D printing process parameters used in the shape and dimensions of the interlocking dove tail with PLA material is stronger, even with the load given. This simulation relates to the maximum capacity of the tensile testing machine to be used. Machine used Zwick/Roell Z020 universal testing machine of 20kN maximum load cell capacity.

After the simulation, it will be more valid if the material is made and a tensile test is carried out. The design dimensions can be changed to a larger dimension value, and using a stronger material. For plastic materials, it is better to use non-linear simulations, so that it is obtained how long the ABS and PLA materials hold against the given load.

References

- [1] P. Song, Z. Fu, L. Liu, and C. W. Fu, "Printing 3D objects with interlocking parts," *Comput. Aided Geom. Des.*, vol. 35–36, pp. 137–148, May 2015, DOI: [10.1016/j.cagd.2015.03.020](https://doi.org/10.1016/j.cagd.2015.03.020).
- [2] L. N. Ikhsanto and Zainuddin, "Analisa Kekuatan Bending Filamen Abs Dan Pla Pada Hasil 3d Printer Dengan Variasi Suhu Nozzle," *Media Mesin J. Imiah Tek. Mesin Vol.*, vol. 21, no. 1, pp. 9–17, 2020, DOI: [10.23917/mesin.v21i1.9418](https://doi.org/10.23917/mesin.v21i1.9418).
- [3] V. Ermolai *et al.*, "Mechanical Behaviour of Macroscopic Interfaces for 3D Printed Multi-material Samples," *MATEC Web Conf.*, vol. 368, p. 01004, 2022, DOI: [10.1051/mateconf/202236801004](https://doi.org/10.1051/mateconf/202236801004).
- [4] K. ÖZSOY, A. ERÇETİN, and Z. A. ÇEVİK, "Comparison of Mechanical Properties of PLA and ABS Based Structures Produced by Fused Deposition Modelling Additive Manufacturing," *Eur. J. Sci. Technol.*, no. 27, pp. 802–809, 2021, DOI: [10.31590/ejosat.983317](https://doi.org/10.31590/ejosat.983317).
- [5] W. H. Pratama, H. -, and H. -, "Optimasi Parameter Proses 3D Printing Terhadap Kuat Tarik Material Filamen PLA + Menggunakan Metode Taguchi," *Sprocket J. Mech. Eng.*, vol. 3, no. 1, pp. 39–45, 2021, DOI: [10.36655/sprocket.v3i1.568](https://doi.org/10.36655/sprocket.v3i1.568).
- [6] Sobron Lubis and D. Sutanto, "Pengaturan Orientasi Posisi Objek pada Proses Rapid Prototyping Menggunakan 3D Printer Terhadap Waktu Proses dan Kualitas Produk," *J. Tek. Mesin*, vol. 15, no. 1, pp. 27–34, 2014, DOI: [10.9744/jtm.15.1.27-34](https://doi.org/10.9744/jtm.15.1.27-34).
- [7] L. Sobron and D. Sutanto, "Pengaruh Posisi Orientasi Objek Pada Proses Rapid Prototyping 3d Printing Terhadap Kekuatan Tarik Material Polymer," *SINERGI*, vol. 20, no. 3, p. 229, Dec. 2016, DOI: [10.22441/sinergi.2016.3.009](https://doi.org/10.22441/sinergi.2016.3.009).
- [8] G. S. Lubis, M. Taufiqurrahman, and M. Ivanto, "Analisa Pengaruh Parameter Proses Terhadap Uji Tarik Produk Hasil 3D Printing Berbahan Polylactic Acid," *J. Engine Energi, Manufaktur, dan Mater.*, vol. 5, no. 2, p. 39, 2021, DOI: [10.30588/jeemm.v5i2.877](https://doi.org/10.30588/jeemm.v5i2.877).
- [9] S. Lubis, M. Taufiqurrahman, and M. Ivanto, "Analisa Pengaruh Parameter Proses Terhadap Uji Tarik Produk Hasil 3D Printing Berbahan Polylactic Acid (1)* Gita Suryani Lubis, (2) Muhammad Taufiqurrahman, (3) Muhammad Ivanto," *J. Engine Energi, manufaktur, dan Mater.*, vol. 5, no. 2, pp. 39–44, 2021. DOI: <http://dx.doi.org/10.30588/jeemm.v5i2.877>
- [10] A. Finali, A. Fauzi Hanafi, R. P. Eko, P. Studi Teknik Mesin, P. Negeri Banyuwangi, and P. Studi Teknik Manufaktur Kapal, "Analisis Variasi Pattern 3D Printing terhadap Kekuatan Tarik," *J-Proteksion*, vol. 5, no. 1, pp. 16–19, 2020, [Online]. Available: <http://jurnal.unmuhjember.ac.id/index.php/J-Proteksion> DOI: <https://doi.org/10.32528/jp.v5i1.4320>
- [11] A. Zamheri, A. P. Syahputra, and F. Arifin, "Studi Penyusutan Pembuatan Gigi Palsu Dengan 3D Printing Fdm Pendekatan Metode Taguchi," *Jurnal Austenit Vol.12 No.2*, Oktober 2020 DOI: <https://doi.org/10.5281/zenodo.4547840>
- [12] J. H. Panjaitan, M. Tampubolon, F. Sihombing, and J. Simanjuntak, "Pengaruh Kecepatan, Temperatur dan Infill Terhadap Kualitas dan Kekasaran Kotak Relay Lampu Sign Sepedamotor Hasil dari 3D Printing," *Sprocket J. Mech. Eng.*, vol. 2, no. 2, pp. 87–99, 2021, DOI: [10.36655/sprocket.v2i2.530](https://doi.org/10.36655/sprocket.v2i2.530).
- [13] S. Sukmawati Shamin, "Perancangan Sistem Jointing Pada Pemanfaatan Limbah Cone Thread Design Of Jointing System On The Utilization Of Waste Cone Thread (A Case Study in Jln Area , Intersection Holis, Bandung)," 2016. https://repository.telkomuniversity.ac.id/pustaka/files/122011/jurnal_eproc/perancangan-sistem-jointing-pada-pemanfaatan-limbah-cone-thread.pdf
- [14] A. Zapciu, G. D. Tascu, and C. G. Amza, "Considerations on 3D printing joints parts," *IOP Conf. Ser. Mater. Sci. Eng.*, vol. 400, no. 2, 2018, DOI: [10.1088/1757-899X/400/2/022061](https://doi.org/10.1088/1757-899X/400/2/022061).
- [15] L. C. S. Nunes, F. W. R. Dias, and H. S. Da Costa Mattos, "Mechanical behavior of polytetrafluoroethylene in tensile loading under different strain rates," *Polym. Test.*, vol. 30, no. 7, pp. 791–796, 2011, DOI: [10.1016/j.polymertesting.2011.07.004](https://doi.org/10.1016/j.polymertesting.2011.07.004).
- [16] M. SOUISA, P.-A. Staf Jurusan Fisika Fakultas MIPA Universitas Pattimura Jl. Ir. M. Putuhena, Kampus Unpatti, "Analisis Modulus Elastisitas Dan Angka Poisson Bahan Dengan Uji Tarik (The Analysis of Modulus of Elasticity and Poisson Number using the Pull Test)," *J. Barekeng Vol. 5 No. 2 Hal. 9 – 14 Anal.*, vol. 5, no. 2, pp. 9–14, 2011. DOI: <https://doi.org/10.30598/barekengvol5iss2pp9-14>
- [17] A. Setiawan, "Stress-Strain Response Material Polymer Poly Lactid Acid dengan Experimental Measurements dan Numerical Simulations," *Tek. STTKD J. Tek. Elektron. Engine*, vol. 6, no. 1, pp. 10–16, 2020, DOI: [10.56521/teknika.v6i1.184](https://doi.org/10.56521/teknika.v6i1.184).
- [18] N. A. Puspitasari and P. Nugraha, "Simulasi Stress Analysis Pembebanan Statis Dengan Bantuan Software SolidWorks Pada Hasil Perancangan Ladder Frame Chassis Mobil Listrik Menggunakan Material AISI 4340," *Semin. Nas. – XX Rekayasa dan Apl. Tek. Mesin di Ind.*, no. November, pp. 25–33, 2021. <https://eproceeding.itenas.ac.id/index.php/ratmi/article/view/758>
- [19] T. Vukasovic, J. F. Vivanco, D. Celentano, and C. García-Herrera, "Characterization of the mechanical response of thermoplastic parts fabricated with 3D printing," *Int. J. Adv. Manuf. Technol.*, vol. 104, no. 9–12, pp. 4207–4218, 2019, DOI: [10.1007/s00170-019-04194-z](https://doi.org/10.1007/s00170-019-04194-z).
- [20] T. Mulyanto and A. D. Sapto, "Analisis Tegangan Von Mises Poros Mesin Pemotong Umbi-Umbian Dengan Software SolidWorks," *J. PRESISI*, vol. 18, no. 2, pp. 24–29, 2017, [Online]. Available: <https://ejournal.istn.ac.id/presisi/article/view/122>
- [21] Y. B. Pratiknyo, "Metode Pengukuran Tegangan Dan Regangan Menggunakan Cad/Cam/Cae Software; Study Komparasi Dengan Universal Testing Machine," *Semin. Nas. Otomasi Ii*, 2005. <http://repository.ubaya.ac.id/40704/3/Yuwono%20Budi%20Pratiknyo%20METODE%20PENGUKURAN%20TEGANGA%20DAN%20REGANGAN.pdf>

- [22] S. Sheppard, "Applying software engineering to simulation," *Simulation*, vol. 40, no. 1, pp. 13–19, 1983, [DOI: 10.1177/003754978304000104](https://doi.org/10.1177/003754978304000104).
- [23] A. I. Pramudi, "Analisis Pengaruh Internal Geometri Terhadap Sifat Mekanik Material PLA Dipreparasi Menggunakan 3D Printing," *Skripsi Tek. Mesin, Fak. Teknol. Ind. Inst. Teknol. Sepuluh Nop.*, pp. 1–57, 2017. https://repository.its.ac.id/42748/1/2713100032_Undergraduate%20Theses.pdf
- [24] Z. Wang, X. Li, and D. Yu, "Computer simulation analysis for Material mechanics," *Appl. Mech. Mater.*, vol. 160, pp. 185–189, 2012, [DOI: 10.4028/www.scientific.net/AMM.160.185](https://doi.org/10.4028/www.scientific.net/AMM.160.185).
- [25] R. V. Petrova, "Introduction to Static Analysis Using SolidWorks Simulation," *Introd. to Static Anal. Using SolidWorks Simul.*, no. May, 2014, [DOI: 10.1201/b17425](https://doi.org/10.1201/b17425).
- [26] Vrtiel, Hajdu, and M. Behúlová, "Analysis of the machine frame stiffness using numerical simulation," *IOP Conf. Ser. Mater. Sci. Eng.*, vol. 266, no. 1, 2017, [DOI: 10.1088/1757-899X/266/1/012015](https://doi.org/10.1088/1757-899X/266/1/012015).