



Development of Remote Programming Practice Module for Mitsubishi RV-M1 Industrial Robot

Eko Aris Budi Cahyono ^{1✉}, Pippie Arbiyanti ², Dian Artanto ³

^{1,2,3}Department of Mechatronic, Faculty of Vocational Study, Sanata Dharma University, Maguwoharjo, Yogyakarta, Indonesia

eko_aris@usd.ac.id

Abstract

This research aims to provide solutions for practical learning in the vocational field of mechatronic engineering during the Covid-19 pandemic. In order for vocational students to become skilled and competent, a considerable number of hours of practice is required. Meanwhile, to prevent the spread of Covid-19, restrictions on face-to-face meetings have been imposed. To make the number of hours of student practice sufficient without having to meet face to face, a remote laboratory is presented, which can be accessed by students easily, anytime and anywhere. The developed remote laboratory uses real equipment, in the form of the Mitsubishi RV-M1 Industrial Robot, which is monitored by 3 cameras, and can be controlled via the internet. The use of a real robot, not a simulation, is intended so that students can feel the experience as if they were practicing the robot directly. This remote laboratory for the practice of programming the Mitsubishi RV-M1 Industrial Robot has been successfully developed and is already being used by mechatronics students at the vocational faculty of Sanata Dharma University. Most of the students gave a good response to this remote laboratory, because students got a new and interesting experience. To demonstrate the effectiveness of this remote laboratory, a comparison is shown of the average time for searching for the position of an object directly and indirectly through the remote laboratory. From the results of the comparison, the average time to search for the position of an object directly ranges from 1-2 minutes, while through a remote laboratory it ranges from 2-3 minutes, which is considered to be within reasonable limits.

Keywords: Practical Learning, Covid-19, Remote Laboratory, Mitsubishi RV-M1, Industrial Robot.

Jurnal Teknologi is licensed under a Creative Commons 4.0 International License.



1. Introduction

The Covid-19 pandemic that has occurred since the beginning of 2020 has led to many restrictions on activities. In the field of higher education, the government issued rules for limiting lecture activities in the form of limited face-to-face or online 100% to prevent the spread of the virus in the campus environment. This is very influential, especially on the implementation of practical lectures that use laboratory equipment that students do not have. Lecturers must develop new methods so that these practical lecture competencies are achieved. [1], [2], [3], [4], [5], [6], [7], [8], [9], [10], [11], [12], [13], [14], [15].

One of the practical courses at the Mechatronics Study Program, Vocational Faculty, Sanata Dharma University is Robotics Practice. The competence of students generated through this practice is that students can manage and control the movement of industrial robots to solve problems in the application of material handling and assembling certain goods. In this practice, students adjust the position and speed, and program the sequential movement of the robot using industrial robots and software in the laboratory. The existence of restrictions on face-to-face lectures makes students unable to use industrial robot hardware and

software in the laboratory. This obstacle causes the targeted robotics practice competencies to be difficult to achieve by students. The need to achieve practical competence for students, gave rise to ideas for writers to create digital innovations for Remote Robotics Practice Modules [16], [17].

Several remote laboratory works have been developed specifically to help prevent and handle the Covid-19 virus. Some have developed PLC Practicum Learning Applications Remotely to Face the Covid-19 Pandemic. The Remote PLC Practicum Learning Application that was developed uses additional devices in the form of software used for computer communication with PLC practicum teaching aids and application software that is used to access computers that are directly connected to teaching aids via the internet network [18], [19], [20], [21], [22].

EDUMEC's remote laboratory network infrastructure is based on a client-server architecture. In this connection, the user provides a virtual private network (VPN) connection to the system via a remote procedure call (RPC) protocol. The system provides users with reservations, based on available days and time slots, to enable experimental performance.

System security is provided by a VPN connection established by Cisco ASA Firewall [23], [24].

Responses from students regarding remote learning PLC (programmable logic controller) with a remote lab system, have also been investigated using survey data collection techniques and quantitative descriptive methods for data analysis. The results of the study show that the remote lab system is easy to use, and they are satisfied with PLC remote learning using remote laboratory [25], [26], [27], [28].

Other studies have also developed new methods for learning mechatronics using remote monitoring and control, based on programmable logic controllers (PLC) and WebAccess. Mechatronics, Web-CAM and PLC modules are integrated with WebAccess for remote laboratory setup. The results of the study allow users to access the Internet for remote monitoring and control of mechatronic modules via a web browser, thereby increasing work flexibility by enabling personnel to control mechatronic equipment from a remote location [29].

Digital Innovation This Remote Robotics Practice Module is designed by utilizing the development of digital technology and the Internet of Things (IoT). This innovation allows users to perform experiments and laboratory assignments over the Internet without having to be near actual equipment. In a traditional proximal laboratory, users interact directly with equipment by performing physical actions (e.g. manipulating with their hands, pressing buttons, turning knobs) and receiving sensory feedback (visual, audio, and tactile). Digital innovation to be carried out, this same interaction takes place at a distance with the help of remote infrastructure. This digital innovation is a new layer between the user and the laboratory equipment. Digital innovation It is responsible for conveying user actions and receiving sensory information from equipment. The stages in making innovations begin with design planning, initial testing, validation and implementation.

The objective of this study is to produce a remote Mitsubishi RV-M1 industrial robot programming practice module. Through this module, the Mitsubishi RV-M1 industrial robot in the robotics laboratory of the Vocational Faculty of Sanata Dharma University can be programmed by students remotely from their homes. The practice of programming industrial robots remotely will minimize physical contact between students in order to avoid the spread of Covid-19 in the campus environment and still be able to increase student competency in programming the Mitsubishi RV-M1 industrial robot.

2. Research Method

Remote Robotics practice module was designed to provide students with programming experience and monitoring of programming results on real Robotics

practice hardware, even though programming is done remotely from home and students do not have Robotics practice hardware. The Remote Robotics Practice Module design that has been developed can be seen in Figure 1 below.

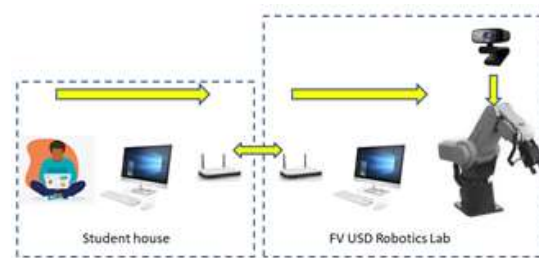

Figure 1. Diagram of Remote Robotics Practice Module Design.

The system that has been developed is as follows.

- In Robotics Laboratory of the Vocational Faculty of Sanata Dharma University, the Mitsubishi RV-M1 Industrial Robot Programming Practice Module, in the work area, was added with pallets that would be used to place the workpieces to be assembled by the robot. In the work area, 3 cameras were installed, namely camera 1, was installed permanently to see the robot's work area as a whole, camera 2 was mounted on a semicircular rail system and the camera can be moved along the rail to see all positions of the workpiece to ensure the relative position of the gripper to the workpiece, in the direction of the Z axis, and camera 3 was installed in the center of the gripper to ensure the position of the gripper relative to the workpiece in the direction of the X and Y axes. The computer used to program the robot was installed with software for programming the robot, monitoring the camera and operating the computer remotely.
- At the student's house, computer software was installed for computer operation in the Robotics laboratory of the Vocational Faculty, Sanata Dharma University from the student's house.
- Practical process: Computers and robots located in the Robotics Laboratory of the Vocational Faculty of Sanata Dharma University should be in an active position. Software for remote operation of laboratory computers was enabled to obtain username and password. Students activated the computer from home, then ran the computer control software remotely and then typed the username and password so that they could operate the campus computer from home.
- Students created the robot program and simulated it first, if the simulation results were correct, then downloaded to the robot to be simulated in real terms on industrial robots on campus. The results could be monitored through the camera view on the campus computer.

e. Both the computers in the Robotics laboratory of the Vocational Faculty of Sanata Dharma University and in the students' homes were connected to the internet.

The system that used to connect the camera drive mechanism in the Robotics practice module with student devices could be seen in Figure 2, which involves the use of Node-RED and Cloud services. With this system, many devices other than computers could be used to connect to the system, including NodeMCU, RaspBerry and Mobile.

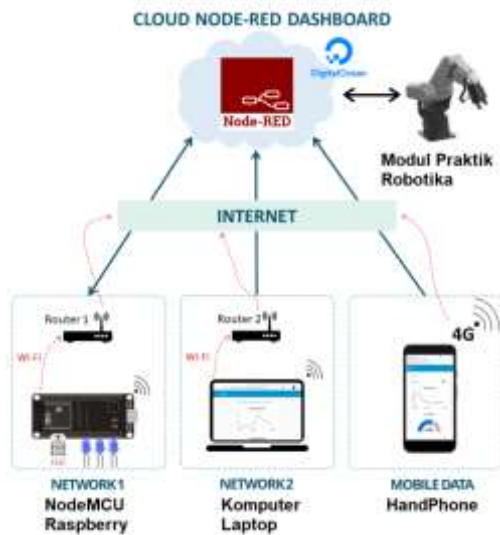

Figure 2. Robotics Practice Module System Design using Node-RED and Cloud.

In the research flow chart, several data collection methods were needed to support the solution in this research, as follows:

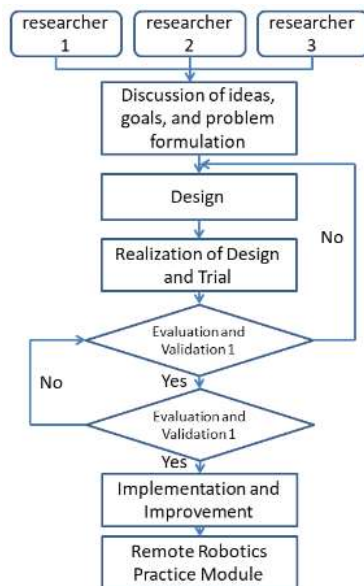

Figure 3. Research method flow plan

Camera 2 could be moved to be positioned according to the appropriate viewing angle as shown in Figure 4 below.

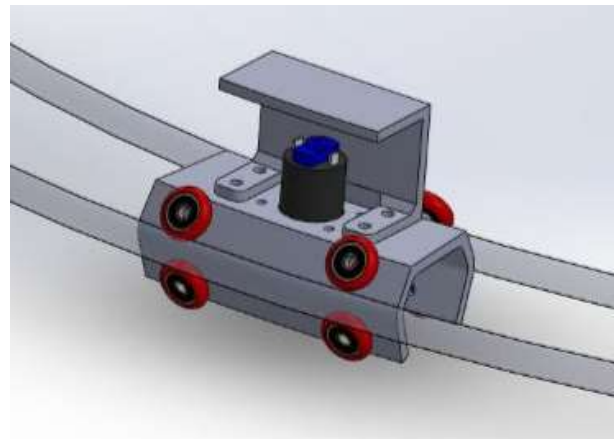

Figure 4. Camera Drive Mechanism

The control flow of the camera drive system could be seen in Figure 5 below.

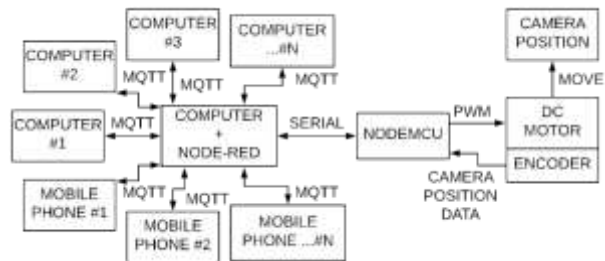

Figure 5. Camera movement control flow

3. Result and Discussion

The final results of the development of the remote programming practice module for the Mitsubishi RV-M1 industrial robot can be seen in Figures 6, 7, 8 and 9 below.



Figure 6. Remote Industrial Robot Practice Module



Figure 7. Three cameras and drive mechanism

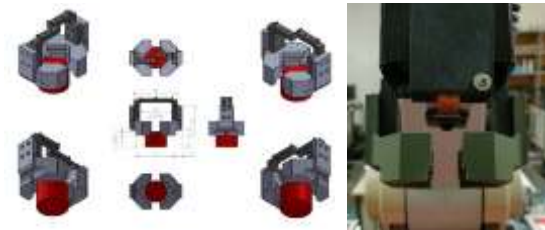

Figure 8. Redesign of gripper



Figure 9. Student Computer Display

Figure 6 shows the hardware of the remote Mitsubishi RV-M1 industrial robot practice learning module that has been developed. Figure 7 shows the three cameras used and shows in more detail the camera drive mechanism that can direct the camera to the desired angle of view. Figure 8 shows the results of the redesign of the gripper to make it easier to visually determine the robot's position. Figure 9 shows the display of a student's computer screen at home. The student computer screen display shows that the Mitsubishi RV-M1 industrial robot in the robotics laboratory can be programmed and its movements monitored from the student's home.

The Remote Robotics Practice Module has a drive mechanism to move camera 2 so that camera 2 can be positioned at different angles of view. The movement of the camera 2 to various viewing angles makes it easier for students to ensure the correct position of the robot when gripping the workpiece in the z-axis direction. The results of the development as shown in Figure 9, show that:

- a. Campus computers can be accessed from student computers remotely via the internet by activating the Anydesk software and entering a password.
- b. The mitsubishi RV-M1 robot can be moved, programmed and simulated by students from campus computers which are accessed by students through their respective computers, using professional cosimir software installed on campus computers.
- c. Robot movement can be monitored through 3 cameras displayed on campus computers that can be accessed from student computers.
- d. Camera 2 can be moved to the desired position by activating the node-red software dashboard (Left, right and stop).

The experimental results of finding the position of the robot to grip the workpiece have been carried out both directly in the robotics laboratory and remotely via the internet. The experiments were carried out 10 times each. The position search experiment was carried out from the same safe position (position 1) then the robot was moved to the desired position. The results of the robot position search experiment were carried out by two records, namely the time it took to find the position and the resulting position (X, Y, Z, P, R). Table 4.1. The following shows the results of position searches, both live position searches in the robotics laboratory and remote position searches via the internet.

Table 1. Comparison of direct and remote robot position search

Position Number	Direct search time	Remote search time	X	Y	Z	P	R
1	Home position		0.1	314.3	465.4	-58.1	179.9
41	Above workpiece		181.3	273.2	300.8	-88.3	179.9
31	01:38		182.2	272.1	258.5	-86.4	179.9
32	01:43		182.4	273.1	258.4	-85.7	179.9
33	01:31		180.4	270.9	257.8	-85.1	179.9
4	01:07		181.4	273	257.7	-85.3	179.9
35	01:25		179.9	272.1	259.4	-85.8	179.9
36	01:27		182	274.4	259	-87.5	179.9
37	01:18		181.3	272.5	258.1	-86.7	179.9
38	01:13		180.3	275.5	262.1	-87.2	179.9
39	01:22		182.2	272.4	258.6	-86.8	179.9
40	01:16		182.2	272.3	258.7	-86	179.9
Average	01:24		181.43	272.73	258.83	-86.2	179.9
51		03:55	179.2	274.7	259.8	-88.1	179.8
52		03:27	181.1	273.9	262.5	-88	179.8
53		03:43	179.6	274.2	262.9	-88	179.8
54		03:50	180.4	274.2	261.9	-88	179.8
55		02:51	179.3	274.6	263.1	-88	179.8
56		02:14	178.8	274.4	263.5	-88	179.8
57		02:29	178.8	273.9	261.1	-88	179.8
58		02:09	179.6	273.2	258.9	-88	179.8
59		01:45	179.3	273.9	262.4	-88	179.8
60		02:06	180	273.3	261.6	-88	179.8
Average		02:50	179.61	274.03	261.77	-88.0	179.8

4. Conclusion

The Mitsubishi RV-M1 robot remote programming practice module has been successfully developed. This practical module has been tested and the result is that the robot is moved, programmed, simulated and monitored its movement remotely via the internet.

Through the results of this test, it can be concluded that the remote programming practice module of the Mitsubishi RV-M1 industrial robot is ready to be used for robotics practice in the Mechatronics Study Program, Vocational Faculty, Sanata Dharma University.

References

- [1] Azad, A. K. M. (2021). Design and Development of Remote Laboratories with Internet of Things Setting. *Advances in Internet of Things*, 11(03), 95–112. <https://doi.org/10.4236/ait.2021.113007>
- [2] Considine, H., Nafalski, A., & Nedic, Z. (2017, June). Remote laboratory environments for smart E-learning. In *International Conference on Smart Education and Smart E-Learning* (pp. 82-91). Springer, Cham. https://doi.org/10.1007/978-3-319-59451-4_9
- [3] Fukumoto, H., Yamaguchi, T., Ishibashi, M., & Furukawa, T. (2021). Developing a Remote Laboratory System of Stepper Motor for Learning Support. *IEEE Transactions on Education*, 64(3), 292–298. <https://doi.org/10.1109/TE.2020.3042595>
- [4] Haack, M., & Jambor, T. N. (2021). Remote Laboratory for Activating Lecture Hall Teaching and Distance Learning. *ACM International Conference Proceeding Series*, 536–542. <https://doi.org/10.1145/3486011.3486511>
- [5] Jawad, M. N., Bhattacharjee, A., Lehmann, R., Busza, A., Perez-Pinera, P., & Jensen, K. (2021). Remote Laboratory Exercise to Develop Micropipetting Skills. *Journal of Microbiology & Biology Education*, 22(1), 1–4. <https://doi.org/10.1128/jmbe.v22i1.2399>
- [6] Kozic, A., Macerauskas, E., & Sakalys, P. (2016, May). Remote laboratory as conceptual model of blended learning. In Society. Integration. Education. *Proceedings of the International Scientific Conference* (Vol. 2, pp. 549-557). <https://doi.org/10.17770/sie2016vol2.1421>
- [7] Letowski, B., Lavayssière, C., Larroque, B., Schröder, M., & Luthon, F. (2020). A fully open source remote laboratory for practical learning. *Electronics (Switzerland)*, 9(11), 1–16. <https://doi.org/10.3390/electronics9111832>
- [8] Martin, S., Fernandez-Pacheco, A., Ruiperez-Valiente, J. A., Carro, G., & Castro, M. (2021). Remote Experimentation through Arduino-Based Remote Laboratories. *Revista Iberoamericana de Tecnologías Del Aprendizaje*, 16(2), 180–186. <https://doi.org/10.1109/RITA.2021.3089916>
- [9] Jakkula, S. K., Endla, P., Dugyala, P., & Kumaraswamy, T. (2020, December). Collaborative learning through virtual labs in engineering education. In *IOP Conference Series: Materials Science and Engineering* (Vol. 981, No. 2, p. 022095). IOP Publishing. <https://doi.org/10.1088/1757-899X/981/2/022095>
- [10] Palmer, C., Roullier, B., Aamir, M., McQuade, F., Stella, L., Anjum, A., & Diala, U. (2022). Digital Twinning remote laboratories for online practical learning. *Production and Manufacturing Research*, 10(1), 519–545. <https://doi.org/10.1080/21693277.2022.2097140>
- [11] Palmer, C., Roullier, B., Aamir, M., Stella, L., Diala, U., Anjum, A., McQuade, F., Cox, K., & Calvert, A. (2021). Virtual reality based digital twin system for remote laboratories and online practical learning. *Advances in Transdisciplinary Engineering*, 15, 277–283. <https://doi.org/10.3233/ATDE210049>
- [12] Pellegrino, L., Sandroni, C., Bionda, E., Pala, D., Lagos, D. T., Hatziargyriou, N., & Akroud, N. (2020). Remote laboratory testing demonstration. *Energies*, 13(9), 2283. <https://doi.org/10.3390/en13092283>
- [13] R, K., M V, R., & D S, P. (2021). Remote Laboratory: Conducting Laboratory Experiments Over the Internet. *International Journal of Innovative Research in Electrical, Electronics, Instrumentation and Control Engineering*, 9(10), 32–38. <https://doi.org/10.17148/ijireece.2021.91006>
- [14] Thorsteinsson, S. E., Andersen, K., Geirsdottir, G., Thorbergsson, H., & Gudmundsson, K. S. (2018). Blended Learning and Remote Laboratories. *Annual Conference, EAEEIE*, 1–4. <https://doi.org/10.1109/EAEEIE.2018.8534200>
- [15] Wang, N., Lan, Q., Chen, X., Song, G., & Parsaei, H. (2020). *Development of a Remote Laboratory for Engineering Education*. CRC Press. <https://doi.org/10.1201/9780429326455>
- [16] Dewi, T., Rusdianasari, R., Kusumanto, R. D., Siproni, S., Septiarini, F., & Muhajir, M. (2021). Autonomous visual servoing for alternately working arm robots. *Kinetik: Game Technology, Information System, Computer Network, Computing, Electronics, and Control*. <https://doi.org/10.22219/kinetik.v6i3.1285>
- [17] Shavetov, S. V., Merkulova, I. I., Ekimenko, A. A., Borisov, O. I., & Gromov, V. S. (2019). Computer Vision in Control and Robotics for Educational Purposes. *IFAC-PapersOnLine*, 52(9), 144–146. <https://doi.org/10.1016/j.ifacol.2019.08.136>
- [18] Brito Palma, L., Brito, V., Rosas, J., & Gil, P. (2017). A virtual PLC environment for assisting automation teaching and learning. *International Journal of Interactive Mobile Technologies*, 11(5), 12–24. <https://doi.org/10.3991/ijim.v11i5.7066>
- [19] Aydogan, H., & Aras, F. (2022). Design, simulation and virtual implementation of a novel fundamental programmable logic controllers laboratory in a 3D virtual world. *The International Journal of Electrical Engineering & Education*, 59(3), 266–281. <https://doi.org/10.1177/0020720919856249>
- [20] Hsieh, S. J., & Hoermann, K. (2009, June). An Integrated Virtual Learning System For A Programmable Logic Controller (Virtual Plc): Current Progress And Future Directions. In *2009 Annual Conference & Exposition* (pp. 14-201). <https://doi.org/10.18260/1-2--5173>.
- [21] Syufrijal, (2020) Development of Interactive PLC Learning Media Based on Virtual Learning. *KnE Soc. Sci.*, vol. 2020, pp. 513–521, <https://doi.org/10.18502/kss.v4i14.7910>
- [22] Setiyadi S., (2020) Pembuatan Aplikasi Pembelajaran Praktikum PLC Secara Daring Menggunakan PLC Omron CPIE Untuk Menghadapi Pandemi Covid-19, *Technologic (11)2*, 2020, <https://doi.org/10.52453/t.v11i2.304>
- [23] Ak, A., Topuz, V., Altıkardeş, A., & Oral, B. (2018). Development of a remote laboratory infrastructure and LMS for mechatronics distance education. *EURASIA Journal of Mathematics, Science and Technology Education*, 14(6), 2493–2508. <https://doi.org/10.29333/ejmste/89947>
- [24] Bajčić, B., Šulc, J., Reljić, V., Šešlija, D., Dudić, S., & Milenković, I. (2018). Remote Laboratory for Learning Basics of Pneumatic Control. In *Online Engineering & Internet of Things* (pp. 144-150). Springer, Cham. https://doi.org/10.1007/978-3-319-64352-6_14
- [25] Takahashi, E. K., & Cardoso, D. C. (2011). Experimentação remota em atividades de ensino formal: um estudo a partir de periódicos Qualis A. *Revista Brasileira de Pesquisa em Educação em Ciências*, 11(3), 185–208. <https://doi.org/10.1109/TE.2008.930095>
- [26] Tukan, F. O. S. P., & Julian, E. S. (2017). Media Pembelajaran Programmable Logic Controller Berbasis Remote Laboratory Menggunakan Jaringan Internet. *Jetri: Jurnal Ilmiah Teknik Elektro*, 15(1), 13-28. <https://doi.org/10.25105/jetri.v15i1.1733>

- [27] Purnomo, R. D., Mulyanti, B., & Kustija, J. (2021, March). PLC (Programmable Logic Controller) distance learning using remote lab system. In *IOP Conference Series: Materials Science and Engineering* (Vol. 1098, No. 4, p. 042014). IOP Publishing. <https://doi.org/10.1088/1757-899x/1098/4/042014>
- [28] Guc, F., Viola, J., & Chen, Y. (2021, July). Digital twins enabled remote laboratory learning experience for mechatronics education. In *2021 IEEE 1st International Conference on Digital Twins and Parallel Intelligence (DTPI)* (pp. 242-245). IEEE. <https://doi.org/10.1109/DTPI52967.2021.9540196>
- [29] Shyr, W. J., Su, T. J., & Lin, C. M. (2013). Development of remote monitoring and a control system based on PLC and webaccess for learning mechatronics. *International Journal of Advanced Robotic Systems*, 10(2), 97. <https://doi.org/10.5772/55363>